

MAIL TO: P.O. BOX 16347 • Louisville, KY 40256-0347
SHIP TO: 3649 Cane Run Road • Louisville, KY 40211-1961
Tel: (502) 778-2731 • 1 (800) 928-PUMP

Visit our website:
zoellerengineered.com

Product information presented here reflects conditions at time of publication. Consult factory regarding discrepancies or inconsistencies.

X61 HD HAZARDOUS LOCATION SERIES

PRODUCT FEATURES CLASS I, DIVISION 1, GROUPS C & D CLASS I, ZONE 1, GROUPS IIA & IIB 3" Vertical Discharge Units



Covered by US Patent Number 6,364,620.

APPLICATIONS:

- Pumping stations
- Storm water removal
- Wastewater transfer
- Industrial waste
- Hazardous locations
- Warning: not for use in acidic atmospheres.



MATERIAL FEATURES PUMP:

- Solids - 2-1/2"(63 mm) spherical capability
- Discharge size - 3" npt vertical
- Seals - dual mechanical silicon carbide / silicon carbide lower and carbon ceramic upper, Buna-N elastomers.
- Moisture detection system
- Construction - cast iron ASTM A-48, Class 30, 30,000# tensile strength, protected with a corrosion resistant baked on epoxy powder coating.
- Balanced concentric pump housing and impeller
- Attaching Hardware - 304 stainless steel
- "O" Ring Seals: Buna-N.
- Ductile Iron Impeller - 2 blade semi-open with top pump out vanes
- Optional:

<input type="checkbox"/> trimmed impeller	<input type="checkbox"/> 3450 rpm high head unit
<input type="checkbox"/> Vortex impeller	<input type="checkbox"/> Non-sparking rail systems
<input type="checkbox"/> silicon carbide seal	<input type="checkbox"/> 50'(15.2 M) power and sensor cables

MOTOR:

- cCSAus rated Class I, Division 1, Groups C & D and Class I, Zone 1, Groups IIA & IIB Construction
- Tested to FM standards 3600 & 3615 by CSA
- 1 Phase - 230 Volt, 1750 RPM
- 3 Phase - 200/230/460 Volt, 1750 RPM
- Stator - Class F insulation and lead wires
- NEMA B design
- Oil-filled motor housing
- Thermal sensor
- Finned cast iron housing for faster heat dissipation
- Ball bearings - upper and lower high carbon chromium steel
- Power and sensor cable length - 25' (7.6 m)

STANDARD FEATURES:

1. 25'(7.6 m) of heavy duty power cord
2. 25'(7.6 m) of heavy duty sensor cord
3. Specially designed splices and potted cord entry system provides strain relief and prevents wicking of liquids into the housing.
4. Lifting lug integral part of housing (orientation 90° from illustrated view)
5. Filled oil-filled explosion proof rated motor housing assures uniform heat distribution, lubricates bearings, and conducts heat for cooler running.
6. Heavy duty explosion proof rated motor features ball bearing construction. Class F motor insulation is double dipped and baked. End connections and lead wires are Class F. At maximum load, winding temperature will not exceed 250 °F (121 °C) with motor housing not submerged.
7. Tandem seals, Silicon carbide / silicon carbide lower and carbon ceramic upper, Buna-N elastomers.
8. Upper and lower high carbon chromium steel ball bearings
9. Stainless steel shaft and hardware resists corrosion

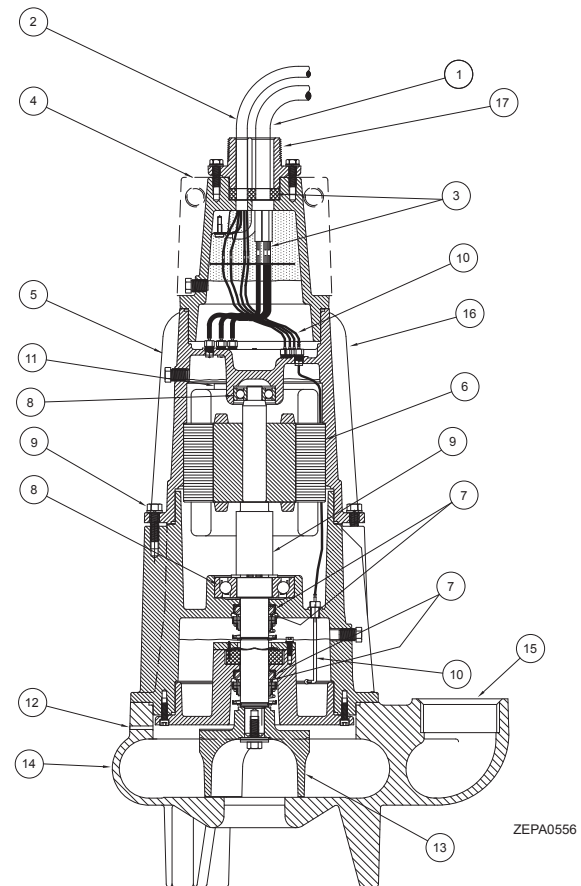

ZEPA0556

10. Patented moisture detection system with upper and lower probes, protecting the motor from liquid entry
11. Thermal sensor will deactivate pump if internal motor temperature reaches 250 °F (121 °C). When connected to panel
12. Vent hole helps prevent air locking
13. Balanced ductile iron 2 vane semi-open impeller with top pump out vanes for seal protection. Keyed and bolted to shaft.
14. Concentric volute reduces radial loading for longer bearing and shaft seal life
15. 3" NPT vertical discharge
16. Entire unit protected with a corrosion resistant powder coated epoxy finish.
17. 2" male NPT conduit connection

For information on additional Zoeller products refer to catalog on Non-sparking rail systems ZM1347; control panels ZM1342; Float switches and brackets ZM1328; pump lifting cables, valves and piping accessories ZM1348.



X61 HD HAZARDOUS LOCATION SERIES

PRODUCT FEATURES

CLASS I, DIVISION 1, GROUPS C & D

CLASS I, ZONE 1, GROUPS IIA & IIB

3" & 4" Flanged Horizontal Discharge Units



Covered by US Patent Number 6,364,620.

APPLICATIONS:

- Pumping stations
- Storm water removal
- All wastewater transfer
- Industrial waste
- Hazardous locations
-  Warning: not for use in acidic atmospheres.



SPECIFICATIONS PUMP:

- Solids - 2-1/2"(63 mm) spherical capability
- Discharge size - 3" & 4" flanged horizontal
- Seals - dual mechanical silicon carbide / silicon carbide lower and carbon ceramic upper, Buna-N elastomers.
- Moisture detection system
- Construction - cast iron ASTM A-48, class 30, 30,000# tensile strength, protected with a corrosion resistant baked on epoxy powder coating.
- Balanced concentric pump housing and impeller
- Attaching hardware - 304 stainless steel
- "O" ring seals: Buna-N
- Ductile iron impeller - 2 blade semi-open with top pump out vanes
- Optional:

<input type="checkbox"/> Trimmed impeller	<input type="checkbox"/> 3450 rpm high head units
<input type="checkbox"/> Vortex impeller	<input type="checkbox"/> (3" discharge units only)
<input type="checkbox"/> Silicon carbide seal	<input type="checkbox"/> 3" (76 mm) solids capacity
<input type="checkbox"/> 50' Power and sensor cables	<input type="checkbox"/> (4" discharge units only)
<input type="checkbox"/> Non-sparking rail systems	

MOTOR:

- cCSAus rated Class I, Division 1, Groups C & D and Class I, Zone 1, Groups IIA & IIB construction
- Tested to FM standards 3600 & 3615 by CSA
- 1 Phase - 230 Volt, 1750 RPM
- 3 Phase - 200/230/460 Volt, 1750 RPM
- Stator - Class F insulation and lead wires Nema B design
- Oil-filled motor housing
- Thermal sensor
- Ball bearings - upper and lower high carbon chromium steel
- Power and sensor cable length - 25' (7.6 M)

STANDARD FEATURES:

1. 25' (7.6 m) of heavy duty power cord
2. 25' (7.6 m) of heavy duty sensor cord
3. Specially designed splices and potted cord entry system provides strain relief and prevents wicking of liquids into the housing.
4. Lifting lug integral part of housing (orientation 90° from illustrated view)
5. Finned oil-filled explosion proof rated motor housing assures uniform heat distribution, lubricates bearings, and conducts heat for cooler running.
6. Heavy duty explosion proof rated motor features ball bearing construction. Class F motor insulation is double dipped and baked. End connections and lead wires are Class F. At maximum load, winding temperature will not exceed 250 °F (121 °C) with motor housing not submerged.
7. Tandem seals, Silicon carbide / silicon carbide lower and carbon ceramic upper, Buna-N elastomers.

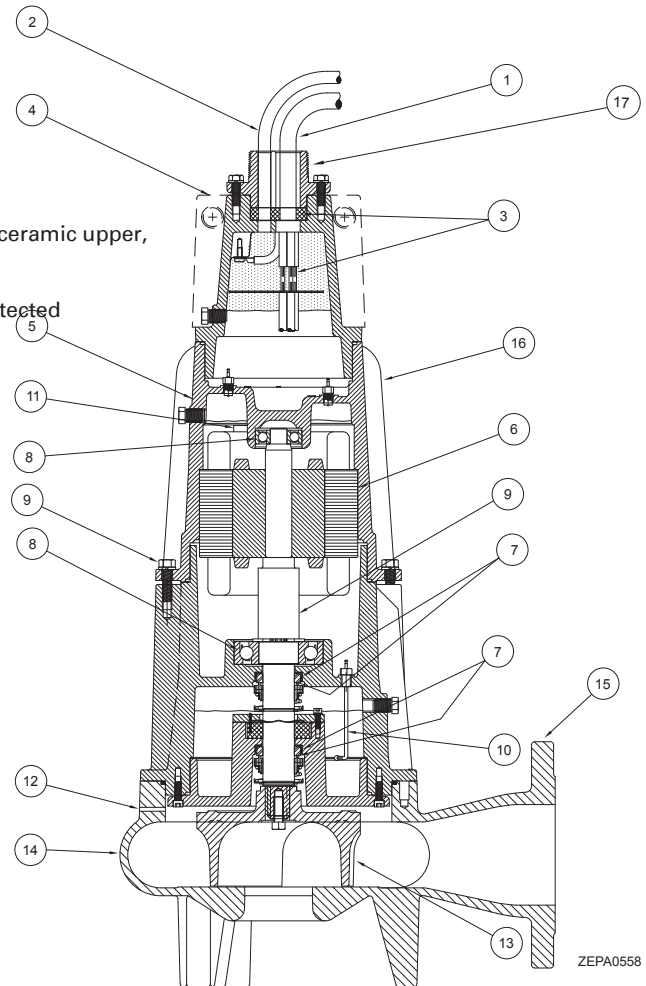

ZEPA0558

8. Upper and lower high carbon chromium steel ball bearings
9. Stainless steel shaft and hardware resists corrosion
10. Patented moisture detection system with upper and lower probes, protecting the motor from liquid entry
11. Thermal sensor will deactivate pump if internal motor temperature reaches 250 °F (121 °C). When connected to panel
12. Vent hole helps prevent air locking
13. Balanced ductile iron 2 vane semi-open impeller with top pump out vanes for seal protection. Keyed and bolted to shaft
14. Concentric volute reduces radial loading for longer bearing and shaft seal life.
15. 3" and 4" flanged horizontal discharge available
16. Entire unit protected with a corrosion resistant powder coated epoxy finish.
17. 2" male NPT conduit connection

For information on additional Zoeller products refer to catalog on non-sparking rail systems and lifting cables ZM1347. control panels ZM1342; float switch brackets ZM1328; check valves and piping accessories ZM1348.