

Trusted. Tested. Tough.®



SECTION: Z5.10.200
ZM3384
0724
Supersedes
0124

MAIL TO: P.O. BOX 16347 • Louisville, KY 40256-0347
SHIP TO: 3649 Cane Run Road • Louisville, KY 40211-1961
Tel: (502) 778-2731 • 1 (800) 928-PUMP

Visit our website:
zoellerengineered.com

Product information presented here reflects conditions at time of publication. Consult factory regarding discrepancies or inconsistencies.

TECHNICAL DATA X6180 HAZARDOUS LOCATION SERIES

Class I, Division 1, Groups C & D Rated and Class I, Zone 1, Groups IIA & IIB Gas Areas
OR
Class II, Division 1, Groups E, F & G and Zone 20 Dust Areas
Commercial Duty Effluent



	<input type="checkbox"/> X6186	<input type="checkbox"/> X6188	<input type="checkbox"/> X6189
PUMP NAME PLATE HORSEPOWER:	1.5 HP	1.5 HP	2 HP
SOLID SIZE: in (mm)	3/4" (19mm)	3/4" (19mm)	3/4" (19mm)
MINIMUM HEAD: ft. (m)	5.0' (1.5m)	5.0' (1.5m)	5.0' (1.5m)
MAXIMUM HEAD: ft. (m)	114' (34.7m)	91' (27.7m)	110' (33.5m)
MAX.FLOW GPM (L/min) @ MIN. HEAD ft. (m)	58 GPM @ 5' (229 L/min @ 1.5m)	145 GPM @ 5' (549 L/min @ 1.5m)	145 GPM @ 5' (549 L/min @ 1.5m)
DISCHARGE SIZE: VERTICAL FEMALE	<input type="checkbox"/> 1-1/2" <input type="checkbox"/> 2" <input type="checkbox"/> 3" NPT	<input type="checkbox"/> 1-1/2" <input type="checkbox"/> 2" <input type="checkbox"/> 3" NPT	<input type="checkbox"/> 1-1/2" <input type="checkbox"/> 2" <input type="checkbox"/> 3" NPT

PUMP NET WEIGHT: lbs (kg)	125-133 (57-60 kg)	MOTOR TYPE CSA APPROVED:	SUBMERSIBLE Class 1 Gas Area Certified Class 2 Dust Area Certified
SERVICE FACTOR:	1.0		
MOTOR DESIGN LETTER:	NEMA B	TYPE SOW POWER CORD LENGTH: ft (m)	25' (7.62m) <input type="checkbox"/> _____'
IMPELLER TYPE:	CAST IRON VORTEX	MOTOR SHAFT:	416 S.S.
SQUARE RINGS:	VITON	STATOR AND LEAD WIRES INSULATION:	X6186 - X6189 CLASS F
RPM:	3450		CLASS B 266 °F (130 °C)
SURFACE TEMPERATURE CODE:	T5 (1PH) T6 (3PH)	MAXIMUM STATOR TEMPERATURE:	CLASS F 311 °F (155 °C)

SHAFT SEAL CONSTRUCTION:	STANDARD	UPPER-CARBON/CERAMIC, LOWER-SILICON CARBIDE/ CARBON
	OPTIONAL <input type="checkbox"/> UPPER <input type="checkbox"/> LOWER	<input type="checkbox"/> SILICON CARBIDE / CARBON <input type="checkbox"/> SILICON CARBIDE / SILICON CARBIDE <input type="checkbox"/> SILICON CARBIDE / SILICON CARBIDE
MOTOR THERMAL SHUTOFF:	STANDARD (Single Phase Only)	THERMAL OVERLOAD WITH AUTOMATIC RESET
MOISTURE DETECTION:	<input type="checkbox"/> OPTIONAL*	MOISTURE SENSING PROBES
MINIMUM RECOMMENDED FLUID LEVEL: in (m)		10" (0.25m)
MAXIMUM WATER TEMPERATURE:		104 °F (40 °C)

*Requires a circuit in control panel to function.

MODEL	HP	200-208V/1PH		<input type="checkbox"/> 230V/1PH		<input type="checkbox"/> 200-208V/3PH		<input type="checkbox"/> 230V/3PH		<input type="checkbox"/> 460V/3PH	
		FLA	LRA	FLA	LRA	FLA	LRA	FLA	LRA	FLA	LRA
<input type="checkbox"/> X6186	1-1/2	17.2	54.5	13.7	45.7	10.3	45.2	9.2	39.4	4.6	19.7
<input type="checkbox"/> X6188	1-1/2	16.8	54.5	14.0	45.7	10.3	45.2	8.9	39.4	4.6	19.7
<input type="checkbox"/> X6189	2	20.5	54.5	17.1	45.7	13.2	45.2	11.2	39.4	6.0	19.7

Refer to reverse side for Head/Capacity Performance Curves

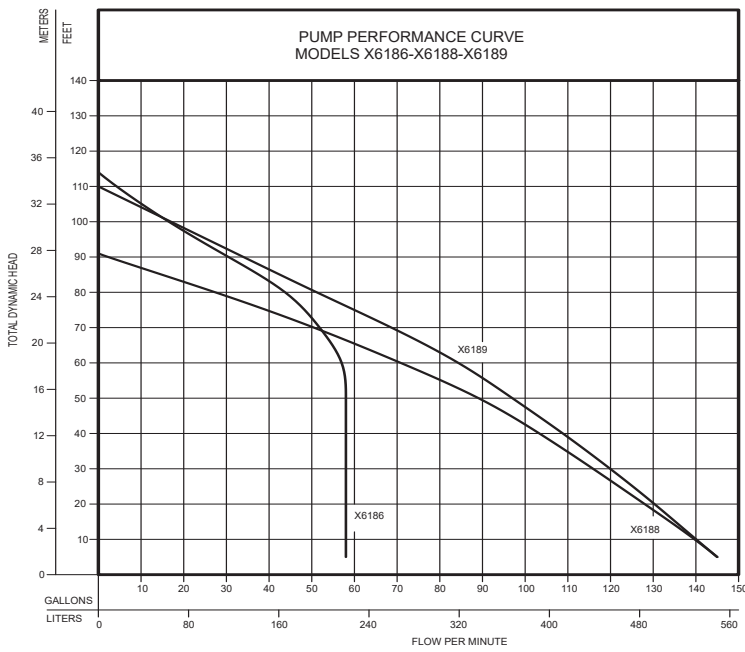

**TOTAL DYNAMIC HEAD/FLOW
PER MINUTE
EFFLUENT AND DEWATERING**

MODELS		X6186		X6188		X6189	
Feet	Meters	Gal.	Liters	Gal.	Liters	Gal.	Liters
5	1.5	58	220	145	549	145	549
10	3.0	58	220	140	530	140	530
20	6.1	58	220	128	484	130.5	494
30	9.1	58	220	116	439	120	454
40	12.2	58	220	103.5	392	109	413
50	15.2	58	220	90	341	97	367
60	18.3	58	220	71	269	85	322
70	21.3	52	197	51	193	69	261
80	24.4	45	170	28	106	51	193
90	27.4	30.5	115	2	8	34	129
100	30.5	16	60	--	--	17	64
110	32	4	15	--	--	--	--
120	36.6	--	--	--	--	--	--
130	39.6	--	--	--	--	--	--
Shut-off Head		114 ft. (35m)		91 ft. (28m)		110 ft. (34m)	

009903

Standard all models - 25 ft. cord - 1.5 HP				
X6186 MODELS	Control Selection			Listings c CSA us
	Volts	PH	Amps	
DX6186	230	1	13.7	Yes
*EX6186	230	1	13.7	Yes
HX6186	200	1	17.2	Yes
IX6186	200	1	17.2	Yes
JX6186	200	3	10.3	Yes
FX6186	230	3	9.2	Yes
GX6186	460	3	4.6	Yes

Standard all models - 25 ft. cord - 1.5 HP				
X6188 MODELS	Control Selection			Listings c CSA us
	Volts	PH	Amps	
DX6188	230	1	14.0	No
*EX6188	230	1	14.0	Yes
HX6188	200	1	16.8	Yes
IX6188	200	1	16.8	Yes
JX6188	200	3	10.3	Yes
FX6188	230	3	8.9	Yes
GX6188	460	3	4.6	Yes

Standard all models - 25 ft. cord - 2 HP				
X6189 MODELS	Control Selection			Listings c CSA us
	Volts	PH	Amps	
DX6189	230	1	17.1	No
*EX6189	230	1	17.1	No ⁽¹⁾
HX6189	200	1	20.5	Yes
IX6189	200	1	20.5	Yes
JX6189	200	3	13.2	Yes
FX6189	230	3	11.2	Yes
GX6189	460	3	6.0	Yes

(1) Factory shipped with 20 amp plug.
* Molded plug

CAUTION

All installation of controls, protection devices and wiring should be done by a qualified licensed electrician. All electrical and safety codes should be followed including the most recent National Electric Code (NEC) and the Occupational Safety and Health Act (OSHA).

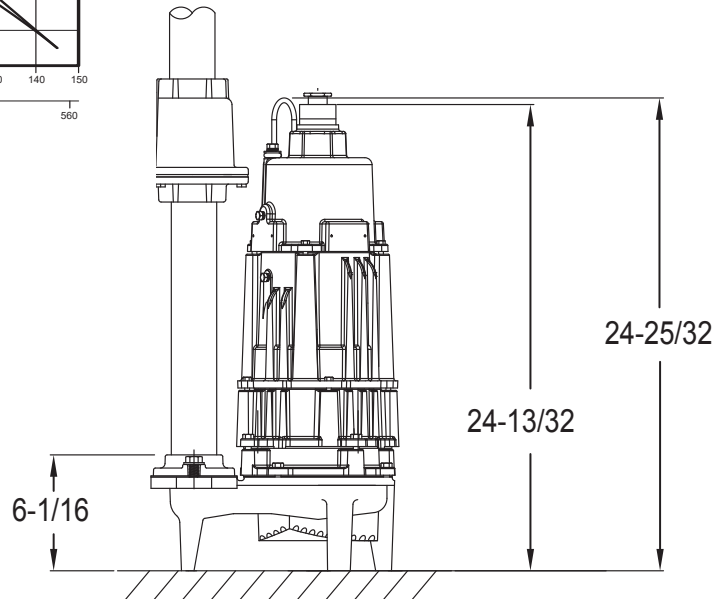

SK1992

FEATURES

- Durable epoxy coated cast iron construction
- Motor - 1.5 - 2 HP, 60 Hz, 3450 RPM, 1 PH or 3 PH, oil-filled, hermetically sealed.
- Thermal sensor with lead wire (3PH), integral overload with automatic reset (1 PH)
- Bearings - upper and lower ball bearings
- Stainless steel motor shaft
- Dual mechanical shaft seals - upper carbon/ceramic, lower silicon carbide/carbon. Optional seal materials available
- Viton square ring seals
- Impeller - non-clogging cast iron vortex design passes 3/4" spherical solids
- 25 foot listed 3 wire neoprene cord and plug. Longer cords available in lengths of 35-50 feet
- No screens to clog
- Stainless steel screws, bolts and handle
- 1-1/2" NPT discharge with 2" or 3" flange available
- Corrosion resistant powder coated epoxy finish
- Moisture sensors available for early warning of seal failure.
- 100% computerized tested.