

Notice to installing contractor: Instructions must remain with installation.

Trusted. Tested. Tough.®



SECTION: Z1.20.145
ZM2670
1024
Supersedes
0524

MAIL TO: P.O. BOX 16347 • Louisville, KY 40256-0347
SHIP TO: 3649 Cane Run Road • Louisville, KY 40211-1961
Tel: (502) 778-2731 • 1 (800) 928-PUMP

Visit our website:
zoellerengineered.com

Product information presented here reflects conditions at time of publication. Consult factory regarding discrepancies or inconsistencies.

OWNER'S MANUAL



Commercial Duty Pumps

| EFFLUENT | SEWAGE |
|--------------------------------------|--|
| 6155, 6161, 6163 6186, 6188, 6189 | 6267, 6284 6292, 6294, 6295 6404, 6405 |

PIN 152575

| Table of Contents | |
|---------------------------------|-----|
| Safety Instructions | 1 |
| Limited Warranty | 2 |
| Preinstallation Checklist | 2 |
| Electrical Data | 3-4 |
| General Information | 4 |
| Pump Wiring Instructions | 5-6 |
| Operation | 7 |
| General Maintenance | 8 |
| Service Checklist | 8 |

| Owner's Information | |
|---|---------------------------------|
| Model Number: _____ | DateCode: _____ |
| <input type="checkbox"/> Simplex | <input type="checkbox"/> Duplex |
| Job Name: _____ | |
| Distributor: _____ | |
| Date of Purchase: _____ | Zoeller S/O No.: _____ |
| Contractor: _____ | |
| Date of Installation: _____ | |
| System Readings During Start-up: Voltage _____ Amps _____ | |

Safety Instructions

TO AVOID SERIOUS OR FATAL PERSONAL INJURY OR MAJOR PROPERTY DAMAGE, READ AND FOLLOW ALL SAFETY INSTRUCTIONS IN THIS MANUAL AND ON THE PUMP.

THIS MANUAL IS INTENDED TO ASSIST IN THE INSTALLATION AND OPERATION OF THIS UNIT AND MUST BE KEPT WITH THE PUMP.

This is a **SAFETY ALERT SYMBOL**. When you see this symbol on the pump or in the manual, look for one of the following signal words and be alert to the potential for personal injury or property damage.

- ▲ DANGER** Warns of hazards that **WILL** cause serious personal injury, death or major property damage.
- ▲ WARNING** Warns of hazards that **CAN** cause serious personal injury, death or major property damage.
- ▲ CAUTION** Warns of hazards that **CAN** cause personal injury or property damage.
- ▲ NOTICE** INDICATES SPECIAL INSTRUCTIONS WHICH ARE VERY IMPORTANT AND MUST BE FOLLOWED.

THOROUGHLY REVIEW ALL INSTRUCTIONS AND WARNINGS PRIOR TO PERFORMING ANY WORK ON THIS PUMP.

MAINTAIN ALL SAFETY DECALS.

REFER TO WARRANTY ON PAGE 2.

LIMITED WARRANTY

Manufacturer warrants, to the purchaser and subsequent owner during the warranty period, every new product to be free from defects in material and workmanship under normal use and service, when properly used and maintained, for a period of 18 months from date of manufacture, 12 months from date of installation or 12 months from the date of start up with a start up report on file with Zoeller. Parts that fail within the warranty period, that inspections determine to be defective in material or workmanship, will be repaired, replaced or remanufactured at Manufacturer's option, provided however, that by so doing we will not be obligated to replace an entire assembly, the entire mechanism or the complete unit. No allowance will be made for shipping charges, damages, labor or other charges that may occur due to product failure, repair or replacement.

This warranty does not apply to and there shall be no warranty for any material or product that has been disassembled without prior approval of Manufacturer, subjected to misuse, misapplication, neglect, alteration, accident or uncontrollable act of nature; that has not been installed, operated or maintained in accordance with Manufacturer's installation instructions; that has been exposed to outside substances including but not limited to the following: sand, gravel, cement, mud, tar, hydrocarbons, hydrocarbon derivatives (oil, gasoline, solvents, etc.), or other abrasive or corrosive substances, wash towels or feminine sanitary products, etc. in all pumping applications. The warranty set out in the paragraph above is in lieu of all other warranties expressed or implied; and we do not authorize any

representative or other person to assume for us any other liability in connection with our products.

Contact Manufacturer at, 3649 Cane Run Road, Louisville, Kentucky 40211, Attention: Customer Support Department to obtain any needed repair or replacement of part(s) or additional information pertaining to our warranty.

MANUFACTURER EXPRESSLY DISCLAIMS LIABILITY FOR SPECIAL, CONSEQUENTIAL OR INCIDENTAL DAMAGES OR BREACH OF EXPRESSED OR IMPLIED WARRANTY; AND ANY IMPLIED WARRANTY OF FITNESS FOR A PARTICULAR PURPOSE AND OF MERCHANTABILITY SHALL BE LIMITED TO THE DURATION OF THE EXPRESSED WARRANTY.

Some states do not allow limitations on the duration of an implied warranty, so the above limitation may not apply to you. Some states do not allow the exclusion or limitation of incidental or consequential damages, so the above limitation or exclusion may not apply to you.

This warranty gives you specific legal rights and you may also have other rights which vary from state to state.

In instances where property damages are incurred as a result of an alleged product failure, the property owner must retain possession of the product for investigation purpose.

PREINSTALLATION INFORMATION

1. **Inspect your pump.** Occasionally, products are damaged during shipment. If the unit is damaged, contact your distributor before using. **DO NOT** remove the test plugs in the motor housing nor the lower seal adapter.
2. **Carefully read the literature** provided to familiarize yourself with specific details regarding installation and use. These materials should be retained for future reference.



SEE BELOW FOR LIST OF WARNINGS

1. Make certain that the receptacle is within the reach of the pump's power supply cord. **DO NOT USE AN EXTENSION CORD.** Extension cords that are too long or too light do not deliver sufficient voltage to the pump motor. But, more important, they could present a safety hazard if the insulation were to become damaged or the connection end were to fall into the sump.
2. **Make sure the pump electrical supply circuit is equipped with fuses or circuit breakers of proper capacity.** A separate branch circuit is recommended, sized according to the "National Electrical Code" for the current shown on the pump nameplate.
3. **Testing for ground.** As a safety measure, each electrical outlet should be checked for ground using an Underwriters Laboratory Listed circuit analyzer which will indicate if the power, neutral and ground wires are correctly connected to your outlet. If they are not, call a qualified licensed electrician.
4. **For Added Safety.** Pumping and other equipment with a 3-prong grounded plug must be connected to a 3-prong grounded receptacle. For added safety the receptacle may be protected with a ground-fault circuit interrupter. When a pump needs to be connected in a watertight junction box, the plug can be removed and spliced to the supply cable with proper grounding. For added safety this circuit may be protected by a ground-fault circuit interrupter. The complete installation must comply with the National Electrical Code and all applicable local codes and ordinances.
5. **FOR YOUR PROTECTION, ALWAYS DISCONNECT PUMP FROM ITS POWER SOURCE BEFORE HANDLING.** Single phase pumps are supplied with a 3-prong grounded plug to help protect you against the possibility of electrical shock. **DO NOT UNDER ANY CIRCUMSTANCES REMOVE THE GROUND PIN.** The 3-prong plug **must** be inserted into a mating 3-prong grounded

- receptacle. If the installation does not have such a receptacle, it must be changed to the proper type, wired and grounded in accordance with the National Electrical Code and all applicable local codes and ordinances. Three phase pumps require motor starting devices with motor overload protection. Refer to ZM1342, Zoeller's simplex and duplex panel selection guide.
6. The tank is to be vented in accordance with local plumbing code. Pumps **must** be installed in accordance with the National Electrical Code and all applicable local codes and ordinances. Pumps are not to be installed in locations classified as hazardous in accordance with National Electrical Code, ANSI/NFPA 70.
 7. Use pressure rated pipe and fittings when connecting to the discharge of the pump.
 8. **"Risk of Electrical Shock"** Do not remove power supply cord and strain relief or connect conduit directly to the pump.
 9. Installation and servicing of electrical circuits and hardware should be performed by a qualified licensed electrician.
 10. Pump installation and servicing should be performed by a qualified person.
 11. Risk of electric shock - These pumps have not been investigated for use in swimming pool and marine areas.
 12. Prop65 warning for California residents: Cancer and reproductive harm- www.P65Warnings.ca.gov.

⚠ CAUTION SEE BELOW FOR LIST OF CAUTIONS

1. Check to be sure your power source is capable of handling the voltage requirements of the motor, as indicated on the pump nameplate.
2. The installation of float switches is the responsibility of the installing party and care should be taken that the tethered float switch will not hang up on the pump apparatus or pit peculiarities and is secured so that the pump will shut off. It is recommended that rigid piping and fittings be used and the pit be 36" or larger in diameter.
3. **INFORMATION - VENT HOLE PURPOSE.** It is necessary that all submersible pumps capable of handling various sizes of solid waste be of the bottom intake design to reduce clogging and seal failures. If a check valve is incorporated in the installation, a vent hole (approx. 3/16") must be drilled in the discharge pipe below the check valve and pit cover to purge the unit of trapped air. Water stream will be visible from this hole during pump run periods. This vent hole should be checked periodically for clogging and cleaned as necessary. Trapped air is caused by agitation and/or a dry basin.
4. Water hammer creates momentary high pressure surges. These surges can cause severe damage to check valves and the piping system. Consideration for water hammer must be included in the piping system design. Reference ASPE Data Book, Chapter 2.33. Some systems may require external spring or lever weighted check valves or other engineered solutions.
5. Three phase pumps must be connected for proper rotation, which is counterclockwise looking into impeller inlet or, refer to the directional arrow on the pump housing.
6. Care should be taken during the initial installation to be sure that adequate air supply is available whenever any person is in the basin. Always follow OSHA guidelines on confined space requirements.

| ELECTRICAL DATA | | | | | | | | | | |
|-----------------|-------|------|---------|-------|-------|-----------|----------|--------------|----------|---------------------------------|
| Model | HP | RPM | Voltage | Phase | Hertz | Amps | | | KVA Code | Winding Resistance Line-to-Line |
| | | | | | | Full Load | Shut Off | Locked Rotor | | |
| N6155 | 1/2 | 3450 | 115 | 1 | 60 | 10.5 | 6.4 | 17.1 | C | 1.92/1.28* |
| E6155 | 1/2 | 3450 | 230 | 1 | 60 | 5.3 | 3.9 | 8.6 | C | 6.06/4.04* |
| N6161 | 1/2 | 3450 | 115 | 1 | 60 | 15.0 | 7.7 | 52.2 | N | .53/.46* |
| J6161 | 1/2 | 3450 | 200 | 3 | 60 | 6.4 | 3.1 | 23.6 | S | 6.1/5.3 |
| F6161 | 1/2 | 3450 | 230 | 3 | 60 | 5.2 | 2.7 | 24.0 | T | 5.5/4.8 |
| G6161 | 1/2 | 3450 | 460 | 3 | 60 | 2.9 | 1.4 | 12.0 | T | 22.1/19.2 |
| N6163 | 1/2 | 3450 | 115 | 1 | 60 | 15.0 | 8.4 | 52.2 | N | .53/.46* |
| J6163 | 1/2 | 3450 | 200 | 3 | 60 | 6.0 | 3.4 | 23.6 | S | 6.1/5.3 |
| F6163 | 1/2 | 3450 | 230 | 3 | 60 | 4.8 | 3.0 | 24.0 | T | 5.5/4.8 |
| G6163 | 1/2 | 3450 | 460 | 3 | 60 | 2.9 | 1.5 | 12.0 | T | 22.1/19.2 |
| E6186 | 1-1/2 | 3450 | 230 | 1 | 60 | 13.7 | 9.3 | 45.7 | H | 1.3/1.1* |
| I6186 | 1-1/2 | 3450 | 200 | 1 | 60 | 17.2 | 11.8 | 54.5 | J | .84/.73* |
| J6186 | 1-1/2 | 3450 | 200 | 3 | 60 | 10.3 | 6.0 | 45.2 | M | 2.5/2.2 |
| F6186 | 1-1/2 | 3450 | 230 | 3 | 60 | 9.2 | 5.5 | 39.4 | M | 3.4/2.9 |
| G6186 | 1-1/2 | 3450 | 460 | 3 | 60 | 4.6 | 2.8 | 19.7 | M | 13.5/11.7 |
| E6188 | 1-1/2 | 3450 | 230 | 1 | 60 | 14.0 | 7.4 | 45.7 | H | 1.3/1.1* |
| I6188 | 1-1/2 | 3450 | 200 | 1 | 60 | 16.8 | 9.8 | 54.5 | J | .84/.73* |
| J6188 | 1-1/2 | 3450 | 200 | 3 | 60 | 10.3 | 4.7 | 45.2 | M | 2.5/2.2 |
| F6188 | 1-1/2 | 3450 | 230 | 3 | 60 | 8.9 | 4.1 | 39.4 | M | 3.4/2.9 |
| G6188 | 1-1/2 | 3450 | 460 | 3 | 60 | 4.6 | 2.0 | 19.7 | M | 13.5/11.7 |
| E6189 | 2 | 3450 | 230 | 1 | 60 | 17.1 | 9.4 | 45.7 | F | 1.3/1.1* |
| I6189 | 2 | 3450 | 200 | 1 | 60 | 20.5 | 11.5 | 54.5 | F | .84/.73* |
| J6189 | 2 | 3450 | 200 | 3 | 60 | 13.2 | 6.8 | 45.2 | J | 2.5/2.2 |
| F6189 | 2 | 3450 | 230 | 3 | 60 | 11.2 | 5.1 | 39.4 | J | 3.4/2.9 |
| G6189 | 2 | 3450 | 460 | 3 | 60 | 6.0 | 2.8 | 19.7 | J | 13.5/11.7 |
| N6267 | 1/2 | 1725 | 115 | 1 | 60 | 10.4 | 6.8 | 25.0 | G | 2.5/1.7 |
| E6267 | 1/2 | 1725 | 230 | 1 | 60 | 5.8 | 3.6 | 12.5 | G | 8.1/7.1* |
| I6267 | 1/2 | 1725 | 200-208 | 1 | 60 | 6.2 | 4.2 | 21.0 | K | 6.4/5.2* |
| J6267 | 1/2 | 1725 | 200-208 | 3 | 60 | 2.6 | 1.9 | 8.3 | G | 14.7/13.1 |
| F6267 | 1/2 | 1725 | 230 | 3 | 60 | 2.6 | 2.0 | 7.1 | G | 18.6/16.2 |
| G6267 | 1/2 | 1725 | 460 | 3 | 60 | 1.5 | 1.1 | 5.1 | K | 49.0/43.0 |

* Line to line reading will only reflect the run winding resistance. Start winding resistance can only be measured after removing the cover.

CONTINUED ON NEXT PAGE

ELECTRICAL DATA, continued

| Model | HP | RPM | Voltage | Phase | Hertz | Amps | | | KVA Code | Winding Resistance Line-to-Line |
|--------|-------|------|---------|-------|-------|-----------|----------|--------------|----------|---------------------------------|
| | | | | | | Full Load | Shut Off | Locked Rotor | | |
| E6284 | 1 | 1725 | 230 | 1 | 60 | 8.9 | 6.7 | 24.9 | G | 2.5/2.2* |
| I6284 | 1 | 1725 | 200 | 1 | 60 | 9.3 | 6.4 | 26.8 | F | 2.0/1.8* |
| J6284 | 1 | 1725 | 200 | 3 | 60 | 5.5 | 4.0 | 26.3 | L | 3.0/2.6 |
| F6284 | 1 | 1725 | 230 | 3 | 60 | 5.0 | 4.0 | 22.2 | K | 4.9/4.3 |
| G6284 | 1 | 1725 | 460 | 3 | 60 | 2.6 | 1.9 | 11.1 | K | 19.0/17.0 |
| N6292 | 1/2 | 3450 | 115 | 1 | 60 | 15.0 | 10.6 | 52.2 | N | .53/.46* |
| F6292 | 1/2 | 3450 | 230 | 3 | 60 | 5.2 | 3.5 | 24.0 | T | 5.5/4.8 |
| J6292 | 1/2 | 3450 | 200 | 3 | 60 | 6.4 | 4.0 | 23.6 | S | 6.1/5.3 |
| G6292 | 1/2 | 3450 | 460 | 3 | 60 | 2.9 | 1.7 | 12.0 | T | 22.1/19.2 |
| E6294 | 1-1/2 | 3450 | 230 | 1 | 60 | 13.7 | 9.7 | 45.7 | H | 1.3/1.1* |
| I6294 | 1-1/2 | 3450 | 200 | 1 | 60 | 17.8 | 11.6 | 54.5 | J | .84/.73* |
| J6294 | 1-1/2 | 3450 | 200 | 3 | 60 | 10.8 | 6.2 | 45.2 | M | 2.5/2.2 |
| F6294 | 1-1/2 | 3450 | 230 | 3 | 60 | 9.5 | 5.6 | 39.4 | M | 3.4/2.9 |
| G6294 | 1-1/2 | 3450 | 460 | 3 | 60 | 4.8 | 2.8 | 19.7 | M | 13.5/11.7 |
| E6295 | 2 | 3450 | 230 | 1 | 60 | 17.1 | 12.0 | 45.7 | F | 1.3/1.1* |
| I6295 | 2 | 3450 | 200 | 1 | 60 | 20.5 | 14.7 | 54.5 | F | .84/.73* |
| J6295 | 2 | 3450 | 200 | 3 | 60 | 14.3 | 8.8 | 45.2 | J | 2.5/2.2 |
| F6295 | 2 | 3450 | 230 | 3 | 60 | 12.2 | 7.5 | 39.4 | J | 3.4/2.9 |
| G6295 | 2 | 3450 | 460 | 3 | 60 | 6.1 | 3.8 | 19.7 | J | 13.5/11.7 |
| E16404 | 2 | 1725 | 200-230 | 1 | 60 | 12.9 | 9.9 | 44.8 | B | 1.80/1.60* |
| F6404 | 2 | 1725 | 230 | 3 | 60 | 10.5 | 9.7 | 44.6 | G | 2.3/2.0 |
| G6404 | 2 | 1725 | 460 | 3 | 60 | 5.2 | 4.8 | 22.3 | G | 9.1/8.0 |
| E16405 | 3 | 1725 | 200-230 | 1 | 60 | 18.0 | 11.3 | 44.8 | B | 1.80/1.60* |
| F6405 | 3 | 1725 | 230 | 3 | 60 | 12.2 | 9.7 | 44.6 | G | 2.3/2.0 |
| G6405 | 3 | 1725 | 460 | 3 | 60 | 6.1 | 4.8 | 22.3 | G | 9.1/8.0 |

* Line to line reading will only reflect the run winding resistance. Start winding resistance can only be measured after removing the cover.

| AWG | ohms/ft | Added Resistance | |
|-----|---------|------------------|------|
| | | 25' | 50' |
| 18 | 0.0064 | 0.16 | 0.32 |
| 16 | 0.0040 | 0.10 | 0.20 |
| 14 | 0.0025 | 0.06 | 0.13 |
| 12 | 0.0016 | 0.04 | 0.08 |

For total resistance including power cable, see chart.

TYPICAL INSTALLATION USING DUPLEX CONTROL PANEL

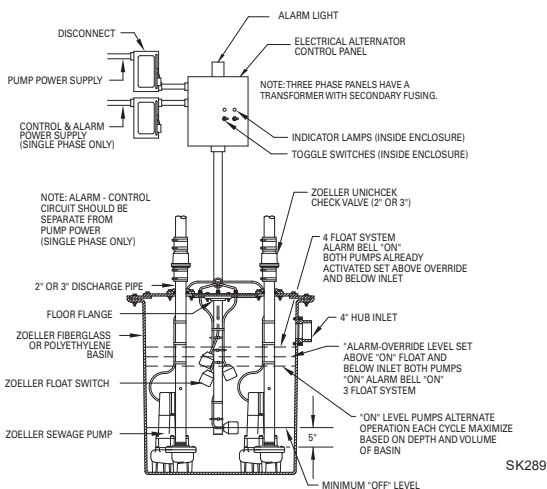

SK289

- (1) Electrical wiring and protection must be in accordance with National Electrical Code and any other applicable state and local electrical requirements.
- (2) Install proper Zoeller unichek (combination union and check valve), preferably just above the basin to allow easy removal of the pump for cleaning or repair. On sewage, effluent or dewatering, if high head or below cover installation is required use 30-0152 on 1-1/2" and 2" pipe and 6030-0160 on 3" pipe. See (6) below.
- (3) All installations require a basin cover to prevent debris from falling into the basin and to prevent accidental injury.
- (4) Gas tight seals are required in all sewage installations to contain gases and odors.
- (5) Vent gases and odors to the atmosphere through vent pipe.
- (6) When a Unichek is installed, drill a 3/16" dia. hole in the discharge pipe even with the top of the pump. NOTE: THE HOLE MUST ALSO BE BELOW THE BASIN COVER AND CLEANED PERIODICALLY (High Head unit see Caution #3 on front page).
- (7) Securely tape or clamp power cord to discharge pipe.
- (8) Locate float switches as shown in sketch to left. The "off" point must be above motor housing and positioned 180° from the inlet.
- (9) Use full-size discharge pipe.
- (10) Basin must be in accordance with applicable codes and specifications.
- (11) Pump must be level and float mechanism clear of sides of basin before starting pump.
- (12) Basin must be clean and free of debris after installation.
- (13) Shut Off Valve to be installed according to any and all codes.

NOTE: See ZM1342 and ZM1536 for Panels, Alarms, Junction Boxes & Floats.

PUMP WIRING INSTRUCTIONS



▲ WARNING Installation and checking of electrical circuits and hardware should be performed by a qualified licensed electrician.

▲ WARNING **RISK OF ELECTRICAL SHOCK** Do not remove power supply cord and strain relief or connect conduit directly to the pump.

▲ CAUTION Power cords, sensor cords, and float cords all must be sealed to prevent gases from the basin entering the control panel.

INSTRUCTIONS FOR CHECKING ROTATION OF THREE PHASE UNITS

It is very important that these units be connected for proper rotation. Since no rotating parts are visible without removing the pump from the pit, the rotation on 3 phase units should be checked before installation into the pit as follows:

After the proper electrical connections are made, momentarily energize the pump observing the direction of kick back due to starting torque. The rotation is correct if the kick back is in the opposite direction of the rotation arrow. If the rotation is not correct, disconnect power and switch any two power leads. Turn power back on and retest for proper rotation. If uncertain, the pump will draw the fewest amps when rotating in the proper direction. Directional arrows are also found on the pump housing.

MOISTURE SENSORS (OPTIONAL FEATURE)

- (1) Pumps with moisture sensors will have a separate small diameter sensor cord in addition to the power cord.
- (2) Sensor cord conductor wires are connected to sensor probes in the lower seal cavity and cap assembly. The conductor wires are terminated in the control panel for activating an indicator light when moisture is present in the lower seal cavity, motor cavity or cord cap assembly.
- (3) When the moisture indicator light is activated the pump should be serviced within 30 days to avoid damage to the motor and bearings.
- (4) Oil in the motor housing and lower seal cavity should be checked when pump is serviced. If oil from the motor housing contains water or other contamination, both seals should be replaced during maintenance. Always replace with new factory recommended oil and service parts. All warranty repairs must be made by Zoeller Authorized Service Stations.
- (5) On existing applications where the control panel only has one moisture sensor hookup per pump, one moisture sensor lead from the pump should be hooked to the moisture sensor lead in the panel, the other moisture sensor lead from the pump should be hooked to ground to complete the circuit.
- (6) The moisture sensor circuit can be checked for continuity (complete circuit) with a (Volt-OHM-Meter). Set the VOM to read resistance and connect the VOM leads to the sensor cord black and white wires. The VOM should read approximately 330k Ohms when the pump is moisture free. Resistance readings significantly lower indicates that moisture has entered into the pump assembly. If VOM reading is open, a problem exists with moisture sensor circuit. Check resistance between the green ground conductor of the pump power cord and the sensor cord black and white wires where the resistance reading should indicate an open circuit. If VOM reading returns a reading other than open, then a problem exists and the pump should be taken to a Zoeller Authorized Service Station.

PUMPS WITHOUT MOISTURE SENSORS

- (1) Double seal pumps offer additional motor protection, but sensor probes are optional.
- (2) Pumps without sensor probes should be inspected on a periodic preventative maintenance schedule.
- (3) The oil in the motor housing and lower seal cavity should be checked when pump is serviced. If oil contains water or other contaminations, both seals and oil should be replaced during maintenance. Always replace with new factory recommended oil and service parts. All warranty repairs must be made by Zoeller Authorized Service Stations.

CONTROL PANELS

These pumps are nonautomatic. They require a control panel. A motor starter circuit, control circuit, and alarm circuit within the panel are standard features. Outdoor enclosures and alternating relays are often required. Variable level float switches are the most common level sensing device. The following should be noted:

3 phase pumps require overload protection in panel. Use with approved motor control that matches motor input in full load amperes with overload element(s) selected or adjusted in accordance with control instructions.

WIRING INSTRUCTIONS

Single Phase



▲ WARNING FOR YOUR PROTECTION, ALWAYS DISCONNECT PUMP FROM ITS POWER SOURCE BEFORE HANDLING. Single phase pumps are supplied with a 3-prong grounded plug to help protect you against the possibility of electrical shock. **DO NOT UNDER ANY CIRCUMSTANCES REMOVE THE GROUND PIN.**

The 3-prong plug **must** be inserted into a mating 3-prong grounded receptacle when not wired into a control panel. If an installation of this type does not have such a receptacle, it must be changed to the proper type, wired and grounded in accordance with the National Electrical Code and all applicable local codes and ordinances.



▲ WARNING RISK OF ELECTRICAL SHOCK Do not remove power supply cord and strain relief or connect conduit directly to the pump.

▲ WARNING Installation and checking of electrical circuits and hardware should be performed by a qualified licensed electrician. Most single phase pumps can be controlled with a wide-angle float switch but, often use a control panel. Refer to ZM1342 for recommended simplex and duplex control panels.

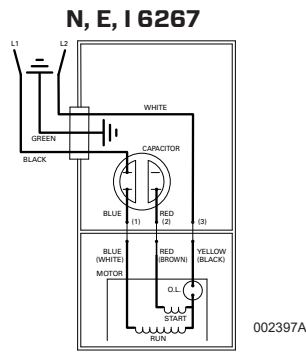
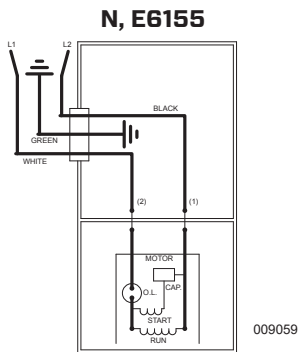

NONAUTOMATIC SINGLE PHASE

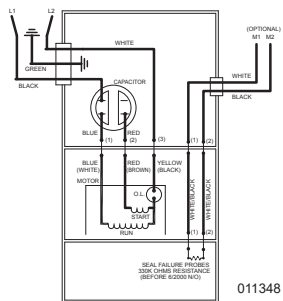

Three Phase



▲ WARNING FOR YOUR PROTECTION, ALWAYS DISCONNECT PUMP FROM ITS POWER SOURCE BEFORE HANDLING. To automatically operate a nonautomatic three phase pump, a control panel is required. Follow the instructions provided with the panel to wire the system.

Before installing a pump, check the pump rotation to insure that wiring has been connected properly to power source, and that the green lead of power cord (See wiring diagram), is connected to a valid ground, momentarily energize the pump, observing the directions of kick back due to starting torque. Rotation is correct if kick back is in the opposite direction of the rotation arrow on the pump casing. If rotation is not correct, switching of any two power leads other than ground, should provide the proper rotation.

All three phase pumps require motor starting devices with motor overload protection. Refer to ZM1342 for recommended simplex and duplex panels.

NONAUTOMATIC 3 PHASE

NONAUTOMATIC THREE PHASE

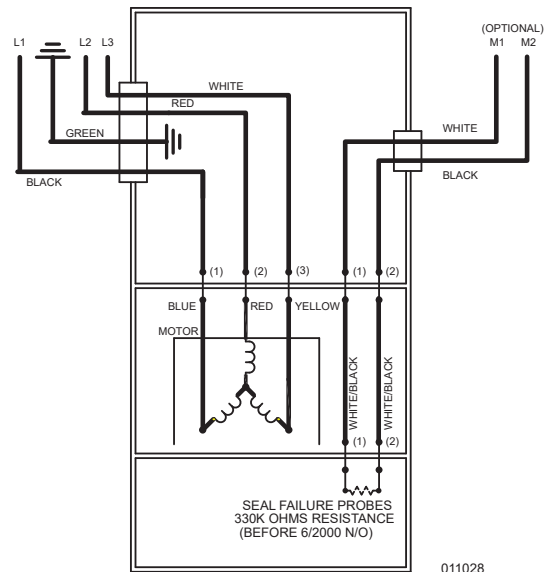

CONTROL PANELS

These pumps are nonautomatic. They typically require a control panel. A motor starter circuit, control circuit, and alarm circuit within the panel are standard features. Outdoor enclosures and alternating relays are often required. Variable level float switches are the most common level sensing device. The following should be noted.

- (1) A pump having the seal failure sensor option requires a panel set up to incorporate this feature.
- (2) All 3 phase pumps require overload protection in panel.

OPERATION

GENERAL

Zoeller pumps are lubricated and tested at the factory prior to shipment and require minimum pre-start-up maintenance.

Maximum operating temperature of pump liquid for standard model pumps must not exceed 130 °F (54 °C). For longest service life all pumps should be totally submerged on long pumping cycles and a maximum of 1/2 hour run time per hour.

These units are not designed to handle liquids other than water or sewage. If pump is used in water contaminated with heavy, viscous, or abrasive materials, the warranty will be voided.

NAMEPLATE DATA

The nameplate, located on the top of pump, indicates specific information about the construction of the pump. The model number, and date code information should be recorded on the front page in the "Owner's Information" section of this manual.

SHORT TERM STORAGE

If pump is to be stored, the following is advised:

- Store pump inside whenever possible or cover with some type of protective covering
- Tape or seal in plastic bag the terminal ends of wire leads
- Spray coat unpainted surfaces with rust inhibiting oil
- The impeller should be rotated every three months in order to keep the seals lubricated and not develop a permanent set

If panel is to be stored, the following is advised:

- Store the panel inside whenever possible and leave in the shipping box
- All openings shall be sealed
- Store in an upright position
- Do not stack anything on top of panel

START-UP PROCEDURE

Before placing the equipment into operation the following checked:

- Correct pump rotation (3 Phase units only)
- Clean pit
- Panel dry and securely installed
- Floats positioned properly
- Discharge valves open
- 3/16" vent hole drilled in pipe between check valve and pump

Once the above has been verified proceed with the following checks:

- Pump power cables properly connected to panel
- Float cables properly connected to panel
- Conduit connections to panel are properly sealed
- Motor overload protection is set in the panel
- After installing the pump into the containment area, with adequate submergence, open the shut-off valve fully. Start the unit using manual controls. If flow is appreciably less than rated performance, pump may be air locked. To expel trapped air, jog the unit several times, using the manual controls
- Have a qualified electrician take voltage and current measurements on the black wire of single phase or all three power wires of three phase with the pump running. Record these readings in the space provided in the "Owner's Information" section on page 1 of this manual for future reference

After the preoperational functional test has been completed, system is ready for operation. Zoeller recommends completing a Start-up Report (ZM1074) whenever a system is started for the first time or after a system has had a significant change take place (i.e. pump replacement, overhaul, etc.). A copy of the Start-up Report should remain with the system for future reference.

ADJUSTMENT PROCEDURE

Pumps: No adjustments are required other than assuring correct rotation.

Panels: The motor overload protection in the panel must be set to the F.L.A. rating on the pump nameplate (or refer to pump data sheet).

Floats: Refer to the system drawing for desired location of each float function.

Valves: Discharge valves should be placed in the fully open position. Systems should not be operated for extended periods of time with the discharge valves partially closed due to damaging the valve.

SHUTDOWN PROCEDURES

If a system is shutdown for more than six months, the following is recommended:

Pumps: If pit is to remain dry, then the pump can remain in the pit. With the pump in the pit, it should be operated for five minutes once every three months. If the pit is to remain wet, the pump should be removed and stored as noted above.

Panels: The panel should have all openings sealed to prevent moisture and dust from entering the enclosure. Prior to restarting system, the panel should be inspected for presence of moisture and any loose connections.

Valves: Consult the valve/actuator supplier for information concerning these systems components.

GENERAL MAINTENANCE

▲ NOTICE Repair and service should be performed by a Zoeller Pump Company authorized service station.

SAFETY PROCEDURES



▲ WARNING For your protection, always disconnect pump and panel from its power source before handling.



▲ WARNING Never enter the basin until it has been properly vented and tested. Any person entering a basin should be wearing a harness with safety rope extending to the surface so that they can be pulled out in case of asphyxiation. Sewage water gives off methane and hydrogen sulfide gases, both of which can be highly poisonous.

Installation and checking of electrical circuits and hardware should be performed by a qualified electrician.

Pump is never to be lifted by power cord.



▲ WARNING Unit must be cleaned and disinfected, inside the pumping chamber and all exterior surfaces, prior to servicing.

GENERAL SYSTEM INSPECTION

Before the system is placed into operation, it should be inspected by a qualified technician. Once in service, regular inspections are recommended.

▲ WARNING Wiring and grounding must be in accordance with the National Electrical Code and all applicable local codes and ordinances.



LUBRICATION PROCEDURES

No lubrication is required.

If pumps are to be stored for more than six months, refer to short term storage procedure in the Operation section.

PREVENTIVE MAINTENANCE

Preventive maintenance is recommended to ensure a long service life from the product. Provided is a suggested maintenance schedule.

Every six months:

- Check for proper and unobstructed float operation
- Listen for proper check valve operation

Every 5 years or 10,000 hours of operation:

- Remove pump, inspect and service using a Zoeller rebuild kit
- Flush and clean basin

DOUBLE SEAL PUMPS

Double seal pumps offer extra protection when the pump is supplied with optional moisture sensors, check the control panel's seal failure light for a warning. Whenever the seal leak light is activated, it's indicating that moisture is present and, the pump should be removed and serviced in order to avoid damage to the motor.

SERVICE CHECKLIST



▲ WARNING Electrical precautions. Before servicing the pump, always shut off the main power circuit. Make sure you are wearing insulated protective sole shoes and not standing in water. Under flooded conditions, contact your local electric company or a qualified licensed electrician for disconnecting electrical service to the pump prior to removal.



▲ WARNING Pumps contain oil which becomes pressurized and hot under operating conditions. Allow 2-1/2 hours after shut down before servicing pump.

| Condition | Common Causes |
|---|---|
| A. Pump will not start or run. | Blown fuse, open circuit breaker, low voltage, no control voltage, thermal overload open, defective capacitor circuit, impeller clogged, float switch held down or defective, incorrect wiring in control panel, water in cap assembly. |
| B. Motor overheats and trips overload. | Incorrect voltage, impeller restricted, negative head (discharge lower than intake of pump). Defective "off" float. Pump runs continuously at low water level. Low oil level in motor shell. Reverse rotation of a 3 phase pump. |
| C. Pump will not shut off. | Air lock, debris under float assembly, defective switch, incoming flow rate exceeds capacity of pump. |
| D. Pump operates but delivers little or no water. | Intake clogged with grease or sludge, pump air locked (clear vent hole), low or incorrect voltage, clogged discharge line, operating near shut-off head. |
| E. Pump starts and stops too often. | Check valve stuck open or defective. Sump pit too small to handle incoming flow rate. Level control out of adjustment. Thermal overload tripping. |
| F. Red beacon comes on at control panel. | High water in pit. Check pump for clogging, or overload trip. See "A", "B" and "D" above. |
| G. Grease and solids accumulate in pit around pump. | Break up solids and run pump with water running into the pit. Allow level to lower to the pump intake. Heavy accumulations of grease may require a dish soap additive. Continue until solids are cleared from the pit. Do not drain kitchen grease down the sink. |