



MAIL TO: P.O. BOX 16347 • Louisville, KY 40256-0347  
SHIP TO: 3649 Cane Run Road • Louisville, KY 40211-1961  
Tel: (502) 778-2731 • 1 (800) 928-PUMP

Visit our website:  
zoellerengineered.com

Product information presented here reflects conditions at time of publication. Consult factory regarding discrepancies or inconsistencies.

ZEP®, The Built To Order Division Of Zoeller Company.



## REPAIR MANUAL

### 61 HD SERIES HEAVY DUTY SOLIDS HANDLING PUMPS

Since 1939 the name Zoeller has represented the standard for submersible dewatering and sewage pumps. The same high quality workmanship and easy maintenance design has been incorporated into this line of heavy-duty solids-handling submersible sewage pumps.

This manual incorporates the parts list and repair instructions into one document to aid in the ownership of a Zoeller submersible non-clog wastewater product. Please read and review this manual before repairing

the product. Follow the steps and procedures listed on ZM1074 for a proper start-up upon installation. Many items contained within, when followed correctly, will not only ensure a long and problem-free life for the pump, but also save time and money during installation. Reference ZM1759 for owner's manual on 61 HD Series Pumps. Should further assistance be necessary please call our Technical Service Department at 1-800-928-PUMP (7867).

#### Table of Contents

Safety Instructions .....	1
Replacement Parts List .....	2-3
Disassembly Procedures .....	4
Assembly Procedures.....	5-6
Pump Wiring Diagrams .....	7
Service Checklist .....	8

#### To Order Replacement Parts

PLEASE FURNISH THE FOLLOWING INFORMATION:

- Model Number
- Part Number of Pump
- Serial Number
- System Voltage
- Replacement Part Number and Description.(refer to pages 2 & 3)

#### Short Term Storage

Storage of six months or less will not damage the submersible pump. However, to ensure the best possible protection, the following is advised:

- Store pump inside whenever possible or cover with some type of protective covering.
- Tape or seal in plastic bag the terminal ends of wire leads.
- Spray coat unpainted surfaces with rust-inhibiting oil.
- See ZM1759 Owner's Manual before start-up.

#### Safety Instructions

**TO AVOID SERIOUS OR FATAL PERSONAL INJURY OR MAJOR PROPERTY DAMAGE, READ AND FOLLOW ALL SAFETY INSTRUCTIONS IN THIS MANUAL AND ON THE PUMP.**

**THIS MANUAL IS INTENDED TO ASSIST IN THE INSTALLATION AND OPERATION OF THIS UNIT AND MUST BE KEPT WITH THE PUMP.**



This is a **SAFETY ALERT SYMBOL**.

When you see this symbol on the pump or in the manual, look for one of the following signal words and be alert to the potential for personal injury or property damage.

**▲ DANGER**

Warns of hazards that **WILL** cause serious personal injury, death or major property damage.

**▲ WARNING**

Warns of hazards that **CAN** cause serious personal injury, death or major property damage.

**▲ CAUTION**

Warns of hazards that **CAN** cause personal injury or property damage.

**▲ NOTICE**

INDICATES SPECIAL INSTRUCTIONS WHICH ARE VERY IMPORTANT AND MUST BE FOLLOWED.

**THOROUGHLY REVIEW ALL INSTRUCTIONS AND WARNINGS PRIOR TO PERFORMING ANY WORK ON THIS PUMP.**

**MAINTAIN ALL SAFETY DECALS.**

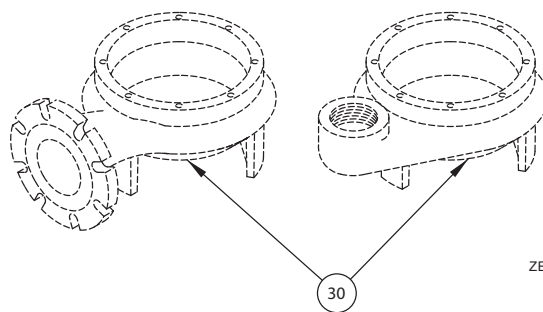
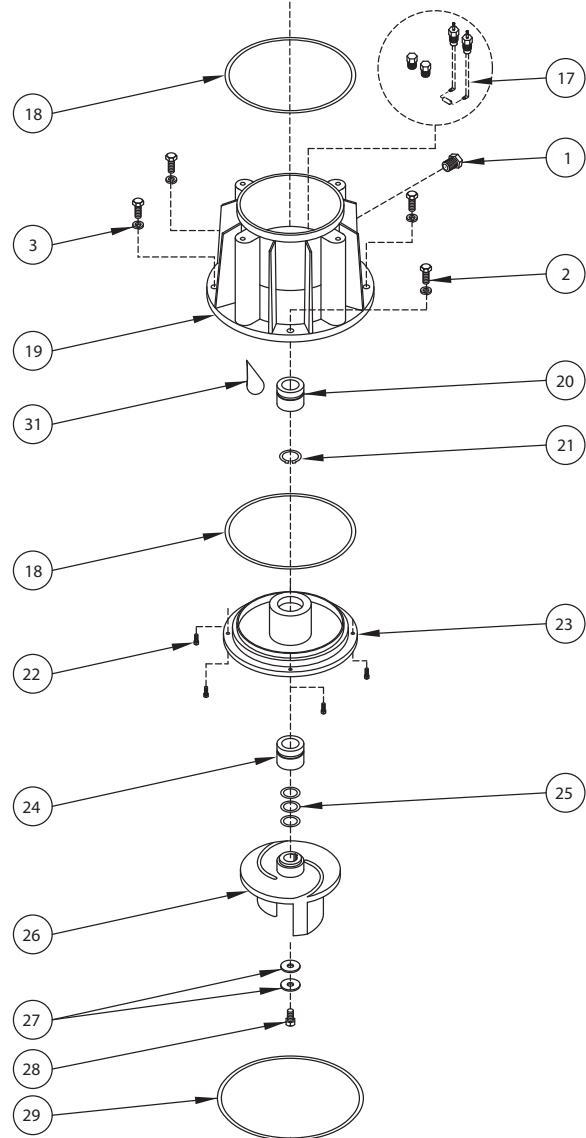
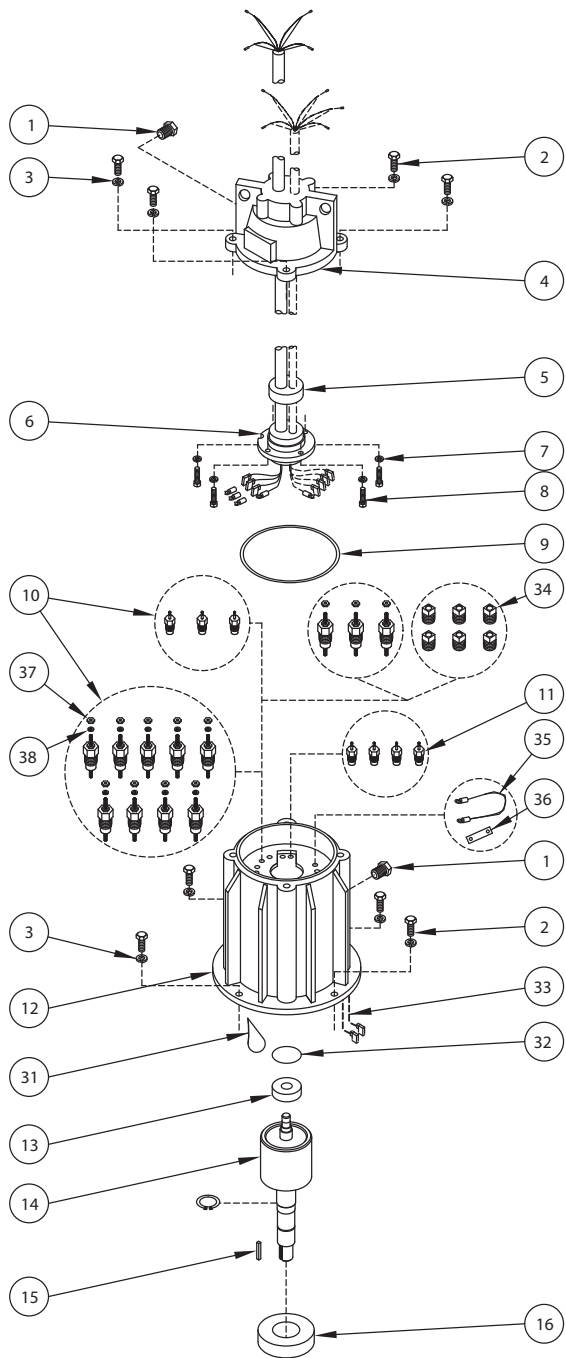

ZEPA0479

**61 HD PARTS LIST**

NUMBER	DESCRIPTION	QTY.	PART NO.
1	PLUG, TEST	3	011162
2	SCREWS	12	006451
3	WASHER, LOCK	12	004497
4	COVER	1	(see job folder for BOM) small or large power cord hole.**
5	CORD SEAL	1	(see job folder for BOM) 12 or 8 ga. with or w/o sensors**
6	CORD AND CLAMP ASSEMBLY	1	(see job folder) 12 or 8 ga. with or w/o sensors (Pin or ring terminals)**
7	WASHER, LOCK	4	002255
8	SCREWS, CORD CLAMP	4	004416
9	SEAL, COVER	1	011157 (standard buna see job folder)
10	THRU WALL TERMINALS, POWER	SEE BOM	(see job folder for BOM)
11	THRU WALL TERMINALS, SENSORS	4	003402
12	MOTOR HOUSING AND STATOR	1	(see job folder for BOM) note: moisture sensor wire must be installed if applicable.**
13	BEARING, UPPER	1	010069
14	ROTOR	1	(see job folder for BOM)
15	KEY, IMPELLER	1	006487
16	BEARING, LOWER	1	008225 (1 Phase) / 011190 (3 Phase)
17	MOISTURE SENSORS/ PLUGS	1	015261 (moisture sensor & wire kit)*
18	SEAL, MTR HSG. / SEAL RETAINER	2	011158 (standard buna see job folder)
19	ADAPTER HOUSING	1	011153
20	ROTARY SEAL, UPPER	1	006510 (standard carbon/ceramic see job folder for bom)
21	SNAP RING	1	006416
22	SCREW, SEAL RETAINER	4	007774
23	SEAL RETAINER	1	011155
24	ROTARY SEAL, LOWER	1	006510 (standard carbon/ceramic see job folder for bom)
25	SHIM PACK	1	011671
26	IMPELLER	1	(see job folder for BOM)
27	WASHER, IMPELLER	2	006488
28	SCREW, IMPELLER	1	006405
29	SEAL, PUMP HOUSING	1	006478 (standard buna see job folder)
30	PUMP HOUSING	1	(see job folder for BOM)
31	OIL	2	008419 (requires (2) one gal. cans)
32	PRELOAD SPRING	1	012595 (after manufactures's Date 2/2000)
33	MOISTURE SENSOR WIRES	1	015261 (moisture sensor & wire kit)*
34	PLUG, TERMINAL HOLES	0 OR 6	016940 (6 REQ'D FOR 200V/3PH AND 230V/1PH)
35	JUMPER WIRE	1	015336( 1 REQ'D 230/460 ONLY)
36	JUMPER PLATE	4	006495 (4 REQ'D 230/460 ONLY)
37	HEX WIRING NUTS	18	013349 (18 REQ'D 230/460 ONLY)
38	WASHER, BRASS	9	013350 (9 REQ'D 230/460 ONLY)

\*One kit required per pump if moisture sensors installed.

\*\*Verify type and size of power lead terminals and thru wall terminals when ordering these components.

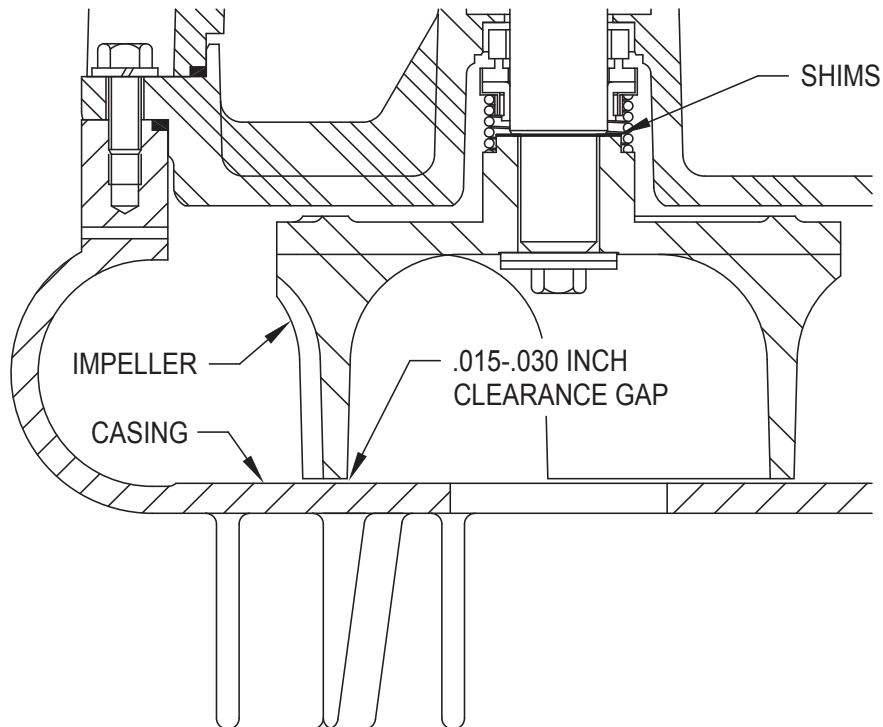

**IMPELLER CLEARANCE DIAGRAM**

© Copyright 2024 Zoeller® Co. All rights reserved.

# Disassembly Procedures

## DUAL VOLTAGE MOTORS

230/460V pump stators are wound so they can be wired for either 230 or 460 volts. New pumps are shipped connected for the specific voltage ordered.

NOTE: When changing the voltage, contact customer experience for updated tags.

To change the voltage, remove the four screws (2) that secure the cover. Lift off the cover (4) being careful not to damage the seal ring (9). Change the wiring as required per the following diagram.

TWO PLATES ARE STACKED ON THESE CONNECTIONS (FROM THE FACTORY) SO THAT THERE ARE 4 PLATES AVAILABLE. 4 PLATES ARE REQUIRED FOR 230 VOLT.

NOTE: ALL 3PH CONNECTIONS  
1. BLACK  
2. RED  
3. WHITE

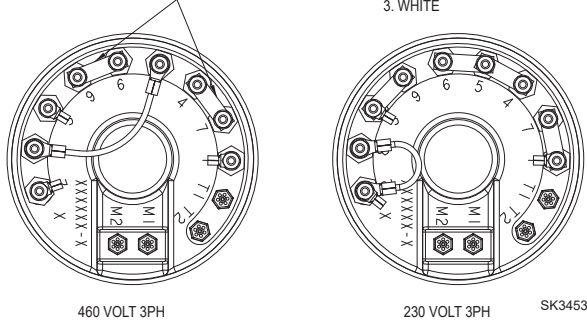

## THREE PHASE STANDARD MOTOR, VOLTAGE OPTIONS WIRING DIAGRAM

After changing the leads, lightly oil the seal ring (9). Ensure that the wire leads will not be pinched and position the cover (4) on the motor housing (12), securing with screws (2).

Before installing a pump into a pit for operation, check the pump rotation, ensure that the wiring has been completed to proper power source and that the green lead of the power and sensor cords (see Power and Sensor Cord Lead identification illustration) is connected to a valid ground. Momentarily energize the pump, observing the direction of kick back due to starting torque. Rotation is correct if kick back is in the opposite direction of rotation arrow on the pump casing. If rotation is not correct, switching of any two power leads should provide the proper rotation (three phase only).

Single phase models are available in 230 volts only and will only run in the proper direction. Therefore, it will not be necessary to remove the lead wire housing.

## OPERATION

Before putting the pump into operation, the following items should be checked to ensure that the pump is installed correctly.

- Electrical connections
- Pump rotation

Loss of performance is usually an indication of wear between the impeller and the casing. The gap created by this wear can be reduced by adding shims as instructed in disassembly and assembly sections of this manual.

## DISASSEMBLY PROCEDURES

### A. Before you begin...

1. Shut off pump.
2. Disconnect power source.
3. Remove pump from system.

### B. When removing impeller (26)...

1. Complete Section A.
2. Remove the four screws (2) and lock washers (3) from the flange of the adapter housing (19).
3. Remove the pump housing (30) and gasket (29).
4. Immobilize the impeller (26) by holding the vanes with a pipe wrench. Using a socket, remove the impeller bolt (28) and impeller washer (27).
5. Using two pry bars, carefully pry the impeller (26) from the shaft.
6. Remove the square key (15) and any impeller shims (25) which are on the shaft.

NOTE: Count the number of shims removed so the same number can be installed upon reassembly.

NOTE: Impeller hub serves as lower seal retainer. When impeller is removed, seal spring will fall free.

### C. When removing rotary seal (20 & 24)...

1. Complete Sections A and B.

**WARNING** Pump should be at room temperature. Seal and motor housing may be pressurized. Care should be used in removing pipe plugs (1) so that oil is not sprayed.

**CAUTION** Do not touch sealing face of the rotating section or the stationary section of the rotary seal (20 & 24) when removing or installing seal. Seal replacement should be done in shop atmosphere if possible.

2. Remove the spring of the lower rotary seal (24) from the shaft. See rotary seal component placement diagram for part identification.
3. Remove the pipe plug (1) in the side of the adapter (19) and drain the oil from the chamber with the pump laying on its side.
4. Remove the four socket head screws (22) from the seal retainer (23).
5. Use two screw drivers to lightly pry the seal retainer (23) from the adapter (19). The remaining part of the lower seal assembly will also be removed.
6. Press seal seat out of the seal retainer (23).
7. Remove the seal ring (18) from the seal retainer and inspect for damage.
8. Slowly remove the oil plug (1) from the side of the motor housing (12). (see warning above)
9. Turn the pump on it's side to drain the motor chamber oil.
10. Remove the upper seal retainer ring (21) from the shaft and remove the spring holder and seal spring of the upper rotary seal (20) from the shaft.
11. Using a bearing puller or other suitable tools, pull the rotating section of the upper rotary seal (20) from the rotor shaft. If needed, carefully pry rotating section loose and pull off by hand.
12. The stationary seal can be pried with a screw driver. Be careful not to chip as chips may fall into motor.

NOTE: If the adapter and motor housing are going to be separated to work on the motor it may be easier to do so before removing the upper seal. When the rotor and bearing are pulled from the adapter it will strip the seal off the shaft on the lower side.

### D. When removing the power and sensor cord assembly (6)...

1. Complete section A.
2. Remove the four screws (2) and lock washers (3) that secure the cover (4) to the motor housing (12).
3. Pry the cover (4) off using two pry bars.
4. Remove the power and sensor cord lead connections from the through wall terminals (10) and (11) in motor housing (12). Set cover and cord assembly aside.
5. Remove seal ring (9) from the cover and inspect for damage.
6. To replace cord assembly. Remove four screws (8) and lock washers (7).
7. Using a small pry bar, pry around the edges of the cord clamp area of the cord and clamp assembly (6) to loosen it.
8. Remove the ground screw and disconnect the ground wire or wires from the inside of the cover (4).
9. Pulling on the power leads on the inside of the cover, remove the cord and clamp assembly (6) and seal (5) from the cover. The entire length of the power and sensor cords will be pulled through the cover.

NOTE: It may take some wiggling and prying to loosen this assembly, because the rubber seal (5) will have taken a set.

10. Inspect the cord seal (5) for damage.

### E. When removing motor rotor (14)...

1. Complete sections A, B, and C. Section D may or may not be completed first. If the cord and cover assembly has been removed, two 3/8" eye bolts will be required when lifting the motor housing and stator off the unit.
2. Place the pump vertical on the work surface. The pump must be blocked or set back in pump housing to allow shaft to extend out the bottom.
3. Remove four screws (2) and lockwashers (3) between motor housing (12) and adapter (19).
4. Lift the motor housing and stator (12) up off the adapter (19), high enough to reach the moisture sensor wires (33) and unplug terminals from moisture sensors (17).

NOTE: Some models may not have moisture sensors.

5. Finish lifting the motor housing (12) off the adapter (19). Be careful to lift the motor housing straight up, so as not to damage the stator windings or bearings.

# Assembly Procedures

6. Remove seal ring (18) from adapter (19) and inspect.
7. Remove bearing pre-load washer (32) from motor housing (12) and inspect.
8. Remove rotor assembly (14) from adapter (19).
9. Using a bearing puller, against the inner race, remove the lower bearing (16) and upper bearing (13) from the shaft. Replace the bearings if needed.

NOTE: Bearings should be cleaned with volatile mineral spirits and relubricated with proper lubricants immediately after cleaning. Never dry bearings with compressed air, and never spin un-lubricated bearings.

## F. Motor Stator...

NOTE: The motor housing and stator assembly removed in Section E number 5, is a factory assembled unit and must be replaced as such: it consists of the motor housing, the glued in stator, the through the wall electrical terminals for the power, and the moisture sensor wires if applicable.

## G. Removing Sensor Studs...

1. Complete Section A, Section C #8, and Section E #6.
2. Unscrew moisture sensors (17) from the adapter (19). If moisture sensor is equipped with a resistor, the resistor must be cut free before unscrewing sensors.

Pumps are reassembled in reverse order of disassembly. The following suggestions are offered.

NOTE: While the pump is dismantled, all gaskets, seal rings and retaining rings should be checked for wear and deterioration. Replace all worn items. Insure that all parts are thoroughly cleaned before assembly.

## A. Installing the sensor studs (17)...

1. Apply oil to threads of sensor studs (17).
2. Apply oil into threaded holes in adapter (19).
3. Screw sensor stud (17) into adapter (19) apply 34 in\*lbs. of torque.
4. Place resistor leads into sensor tubing and crimp tubing.

## B. Assembly of rotor (14)...

1. Inspect rotor to see that the snap ring is in place and snapped into the groove. This snap ring serves as a locator for the lower bearings.

NOTE: Before installing the bearing, wipe the bearing seats on the shaft clean and coat the seats with oil to prevent galling of the shaft as the bearings are pressed onto the shaft. A properly sized pressing sleeve should be used to install bearings, with pressure being applied to only the inner bearing race.

2. Install the lower ball bearing (16) and the upper ball bearing (13) on the rotor shaft (14).
3. Set the adapter (19) on blocks to allow the rotor shaft to clear the work surface when installed.
4. Install the rotor/bearings assembly into the adapter housing (19). Make sure the lower bearing is seated in the bearing pocket.

## C. Installing the motor housing/stator (12)...

NOTE: The motor housing/stator assembly is furnished from the factory as a glued in unit. The assembly will include the motor housing, the stator prewired to installed through wall terminals (10) and moisture sensor wires (33) and terminal hole plugs if applicable.

1. Lightly oil and position the seal ring (18) around the pilot shoulder of the adapter (19).
2. Install the pre-load washer (32) in the upper bearing pocket of the housing/stator unit (12). The pre-load washer should be stretched a little to allow it to remain in the pocket when turned upside down.
3. With the rotor/adapter assembly in the vertical position suspend the motor housing/stator unit over it. Slowly lower the unit aligning the rotor and stator opening. If moisture sensors are present plug the terminals of the wires (33) onto the sensor (17) at this time.
4. Tuck the moisture sensor wires away from the rotor while lowering the motor housing/stator unit into place on the adapter.
5. Secure the motor housing/stator (12) to the adapter (19) with four screw (2) and four lock washers (3). Torque screws to 175-195 in-lbs.

NOTE: The small arrow heads on housing flanges are to be aligned for proper orientation.

## D. Installing cord and cover assembly...

NOTE: The cord(s) will come from the factory as a cord(s) and clamp assembly (6). The assembly consist of the power cord, the sensor cord if applicable, the wire terminals, the clamp and the potting compound between the cords a clamp.

1. Unroll the cords of the cord and clamp assembly (6) and slide the cord seal (5) down the cords to the clamp.
2. From the inside of the cover (4) place the cords of the assembly (6) through the holes and pull through the top.
3. Push the cord seal (5) into it's pocket inside the cover (4). Push the clamp (6) tight against the seal.
4. Apply thread locker compounds to the screws (8) and install into clamp along with lock washers (7). Using a cross pattern, tighten the screws to the seal clamp evenly. Torque screws to 69-72 in-lbs.
5. Apply thread locker compound to ground screw and install ground wires to cover.
6. Lightly oil and install seal ring (9) on shoulder of cover (4).
7. Suspend the cord and cover assembly over the motor housing and make wiring connections per the proper wiring diagram.

NOTE: The power wiring goes to the numbered terminal, the moisture sensor to M1 and M2 and the thermosensor to T1 and T2.

NOTE: If motor is dual voltage 230/460V, install jumper plates (36) and jumper wire (35) on terminals (10) and secure with brass hex nuts (37) and lock washers (38) per proper wiring connection diagram.

8. Tuck the wires in the cover assembly as installing the cover into place.
9. Secure the cover (4) to the motor housing (12) with four screws (2) and four lock washer (3). Torque screws to 175-195 in-lbs.

NOTE: The small arrow heads on the castings are to be aligned for proper orientation.

## E. Installation of rotary seals and seal retainer

**▲ CAUTION** Make sure all seal faces remain free of dirt particles. Apply a light coat of oil to seal faces before installing.

1. Refer to rotary seal component placement diagram for relative positioning of seal parts.
2. Apply a coating of oil to the seal seat and the bore of the adapter (19), and using a nonmetallic sleeve, press the seat into position in the adapter.

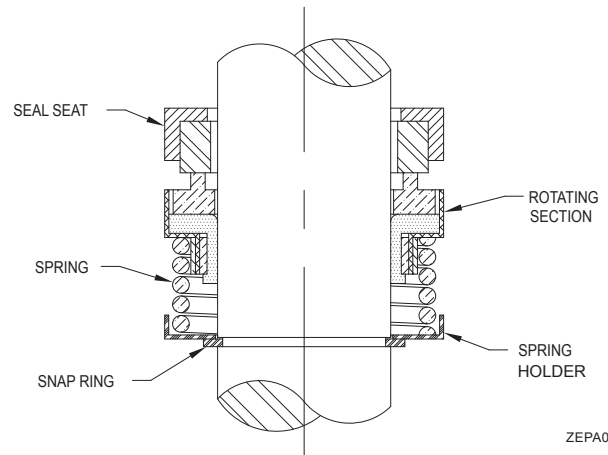

### UPPER ROTARY SEAL COMPONENT PLACEMENT DIAGRAM

(Lower rotary seal is same except impeller hub serves as spring holder and snap ring)

3. Apply 80-90 weight gear oil to the shaft and to the inside diameter of the rotating section of rotary seal (20). Push the rotating section onto the shaft in a continuous motion until the seal faces meet.
4. Install the spring and spring holder over the shaft and seat against the rotating section. Compress the spring as necessary and install retaining ring (21) in the groove of the motor shaft.
5. Lightly oil and install seal ring (18) on the seal retainer (23).
6. Press the seal retainer (23) into the adapter (19) and secure with the four socket head screws (22).

## Assembly Procedures (continued)

7. Install the seal seat and rotating section of the lower rotary seal assembly (24) into the seal retainer (23) in the same manner described in steps 2 and 3 above.

### F. Installing the impeller...

1. Install the spring of the lower rotary seal (24) on the exposed end of the rotor/shaft.

NOTE: Spring holder not required on lower rotary seal.

2. Install the proper number of impeller shims (25) on the shaft to give the face of the impeller (26) a clearance of 0.015 to 0.030 inch with the wearing face of the pump housing (30). (See impeller clearance diagram.)
3. Install the square key (15) in the groove in the shaft.
4. Install the impeller (26) and impeller washers (27).
5. Secure the impeller (26) by immobilizing it, use a pipe wrench to grip the vanes and install the impeller bolt (28), with thread locking compound, in the end of the shaft. Torque bolt to 230-240 in-lbs.
6. Lightly oil and install the seal ring (29) on the adapter (19) and install the adapter on the pump housing, securing it with the four screws (2) and lock washers (3).

### Leak Test

(Before oiling pump) Perform a leak test on the pump seals by installing a regulated air supply into the holes (1/4" NPT access) the motor chamber, seal chamber and cover chamber must be checked. The pressure of the air supply should be set at approximately 9 psi. Submerge the pump in clear water watching for small air bubbles around square ring seals, rotary seal, cord connection, and oil fill plugs.

NOTE: Make certain that the pump is placed in the water so that no areas are present that would trap air (such as the cavity around the lower rotary seal), not allowing the bubbles to rise to the water surface.

If it is not possible to leak test the pump using the submersion method, a regulated air supply with a (0-15 psi) air gage can be installed in the fill holes. The pump to be pressurized and held at 9 psi. After removing the air supply, the pressure should not drop more than 1/2 psi in a 24 hour period.

### G. Oiling and final assembly.

1. After leak testing has been completed, clean pipe plugs and reapply pipe dope or teflon tape. Install pipe plug (1) in cover (4).
2. The following electrical tests must be performed:
  - a) Using a Hypot or Megger, test all leads to case ground.
  - b) Check that there is continuity from the ground wire(s) to ground.
  - c) Check that there is no continuity from all lead wires to ground.
  - d) Check that there is continuity between the thermo sensor wires,
  - e) Check that the resistance between the moisture sensor wires is 330K ohms.
3. With the pump laying on its side with the oil fill hole up, fill the seal chamber cavity with an anti-wear non-detergent, rust inhibiting, paraffining oil of approximately 100 SUS. (See table below for acceptable type of oil.)

Refiner	Product Name
Arco	Duro 22 or 32
Exxon	Teresstic 22 or 32 or acceptable equal
Chevron	Clarity Hydraulic Aw ISO22 or ISO32

4. Clean pipe plugs and reapply pipe dope or teflon tape. Install pipe plug (1) in adapter (19).
5. While pump is on it's side place approximately one quart of oil in motor housing. (Use the same oil as used in the seal cavity.)
6. Set the pump upright and finish filling the motor chamber with oil until it runs back out the fill hole. With the oil running out the fill hole the oil will be at the proper level for the top bearing.
 

**⚠ WARNING** Do not over fill.
7. Clean pipe plug and reapply pipe dope or teflon tape. Install pipe plug (1) in motor housing (12).

## START KITS AND COMPONENTS FOR SINGLE PHASE 61 HD SERIES

PART #	DESCRIPTION
10-0918	KIT, STARTER MODEL 6111
012869	CAPACITOR, 50UF / 370 VAC
015155	RELAY, GE 3ARR22J10A2
012870	CAPACITOR, 270-324UF / 220-250V

PART #	DESCRIPTION (BEFORE 10/1/07)
10-0916	KIT, STARTER MODELS 6120 / 6121
015030	CAPACITOR, 40UF / 370 VAC
007453	RELAY, UNIVERSAL SUPCO
007597	CAPACITOR, 324-389UF / 110-125V

PART #	DESCRIPTION (AFTER 10/1/07)
10-2220	KIT, STARTER MODELS 6120 / 6121
015030	CAPACITOR, 40UF / 370 VAC
018967	RELAY, GE 3ARR3J4A2
008190	CAPACITOR, 216-259UF / 220-250V

PART #	DESCRIPTION
10-0917	KIT, STARTER MODELS 6122 / 6123
012869	CAPACITOR, 50UF / 370 VAC
015156	RELAY, GE 3ARR22J6C2
012870	CAPACITOR, 270-324UF / 220-250V

PART #	DESCRIPTION
10-1433	KIT, STARTER MODELS 6124
012869	CAPACITOR, 50UF / 370 VAC
015154	RELAY, GE 3ARR22J9R2
012870	CAPACITOR, 270-324UF / 220-250V

# Wiring Diagrams

## 3 PHASE 61 HD SERIES

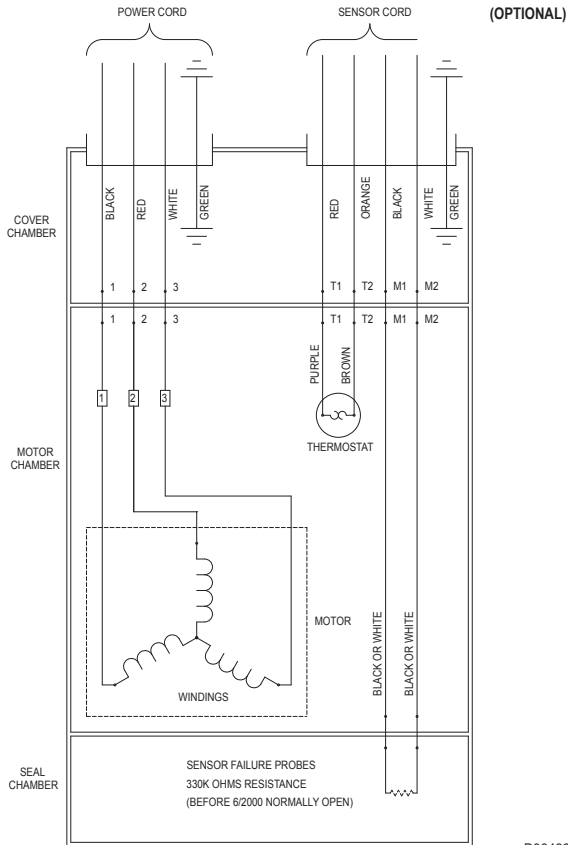

## SINGLE PHASE 61 HD SERIES

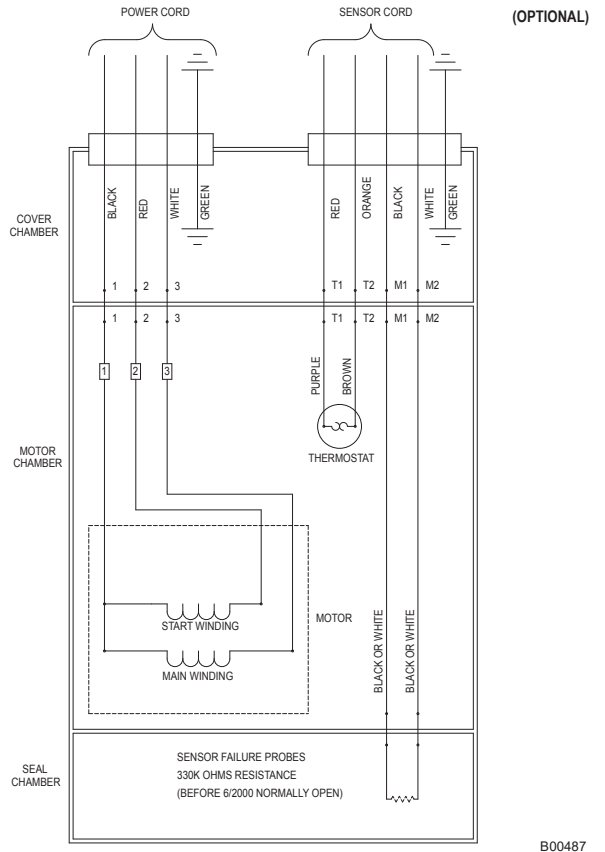

### WIRING COMPONENT LAYOUT SINGLE PHASE MODELS 6120 / 6121 USING SUPCO PR90 RELAY BEFORE 10/1/07

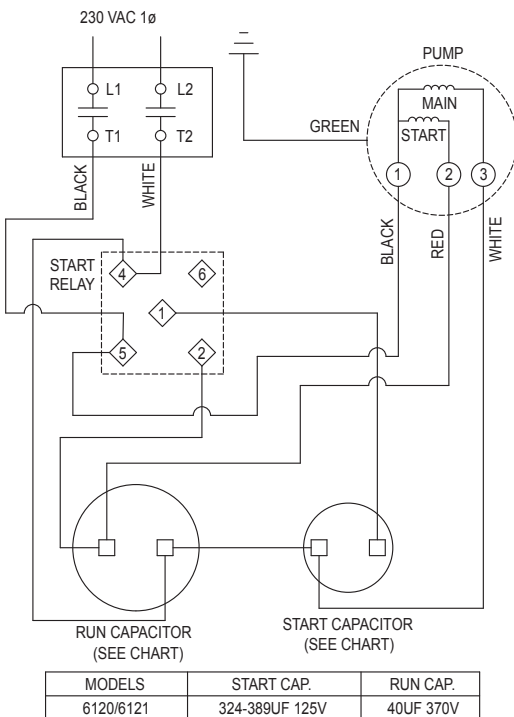

### WIRING COMPONENT LAYOUT SINGLE PHASE MODELS 6111 / 6122 / 6123 / 6124 AND 6120 / 6121 USING GE RELAY AFTER 10/1/07

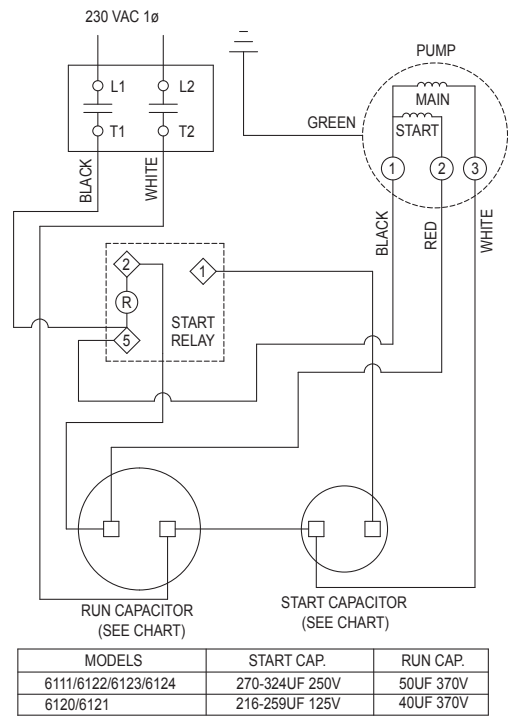

## Service Checklist & Trouble Shooting



**⚠ WARNING**

**ELECTRICAL PRECAUTIONS**

Before servicing a pump, always shut off the main power breaker to the panel and then disconnect the pump - making sure you are wearing insulated protective sole shoes and are not standing in water. Under flooded conditions, contact your local electric company or a qualified licensed electrician for disconnecting electrical service prior to pump removal.

**⚠ WARNING**

Submersible pumps contain oils which become pressurized and hot under operating conditions - **allow 2-1/2 hours after disconnecting before attempting service.**

**CONDITION**

**A. Pump will not start or run.**

Steps	Check Voltage At	If No Voltage	If Voltage
No. 1	Line terminals in pump's control panel L1 - L2 - L3 (3 Phase).	Check Disconnect switch, line fuse, and/or circuit breakers in power supply circuit.	Proceed to No. 2.
No. 2	Pump motor terminals in pump's control panel T1 - T2 - T3.	Check for control circuit voltage. Check out magnetic starter contacts, thermal overloads, and float switches.	Check starting relay and capacitor (1 phase units). Check pump for ground, and binding impeller.

**B. Motor overheats and trips overload or blows fuse.**

**COMMON CAUSES**

- Incorrect Voltage
- Unbalanced power source
- Incorrect motor rotation
- Negative or low head
- Excessive water temperature
- Impeller or seal mechanically bound
- Defective capacitor or relay
- Motor shorted
- Lost one line in a Three Phase unit

**C. Pumps starts and stops too often.**

- Check valve stuck open
- Level controls out of adjustment
- Temperature sensor tripping
- Thermal overload switch out of adjustment or defective
- Pit too small

**D. Pump will not shut off.**

- Debris under float switch
- Float travel obstructed
- Defective or damaged float switch
- Magnetic starter contacts shorted
- Air lock - check vent hole

**E. Pump operates but delivers little or no water.**

- Check for plugged Pump housing, discharge pipe or sticking check valve
- Vent hole clogged or not drilled
- Discharge head exceeds pumps capacity
- Low or incorrect voltage
- Incorrect motor rotation
- Defective capacitor

**F. Drop in head and/or capacity after a period or use.**

- Increase Pipe Friction
- Clogged line or check valve
- Abrasive material & chemical, deteriorated impeller and pump housing

**If the above check list does not uncover the problem, consult the factory - Do not attempt to service or otherwise disassemble pump.**