

MAIL TO: P.O. BOX 16347 • Louisville, KY 40256-0347
SHIP TO: 3649 Cane Run Road • Louisville, KY 40211-1961
Tel: (502) 778-2731 • 1 (800) 928-PUMP

Visit our website:
zoellerengineered.com

Product information presented here reflects conditions at time of publication. Consult factory regarding discrepancies or inconsistencies.

1.0 - 2.0 HP SIMPLEX GRINDER PACKAGE

MODELS 7008, 7010, 7011 & 7013

PREPACKAGED Z-RAIL® DISCONNECT SYSTEM, FIBERGLASS BASIN

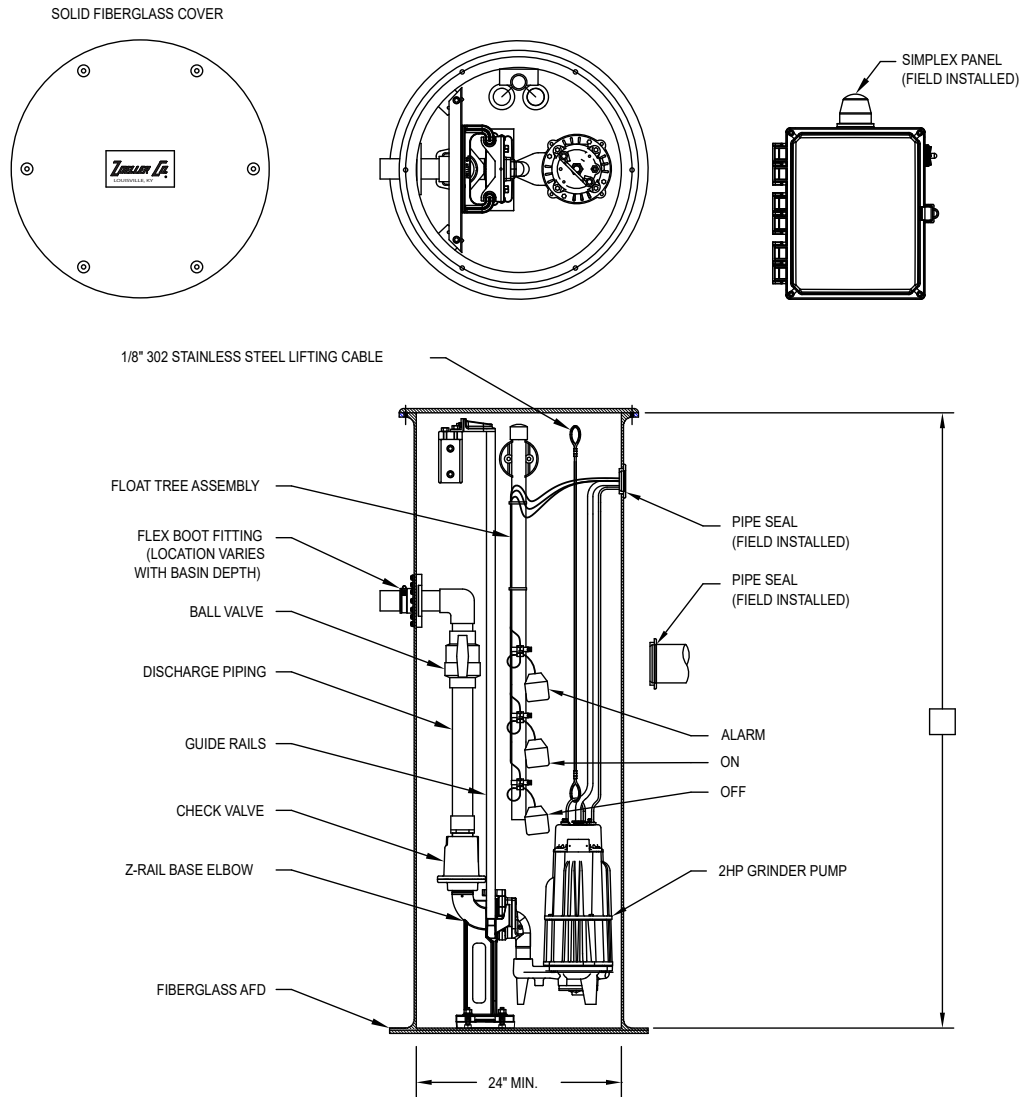

SK3110

Typical Simplex System Includes:

- 1 1.0, 1.5 or 2.0 HP centrifugal grinder pump, nonautomatic
- 1 Control panel or high water alarm
- 1 Junction box (optional, not shown)
- 2 or 3 Pump control and alarm floats
- 1 Fiberglass basin with solid cover, rail system, valves, discharge piping, float tree and stainless steel lifting cable

1.0 & 2.0 SIMPLEX GRINDER PACKAGE

MODELS 7020 & 7021 PROGRESSING CAVITY

PREPACKAGED WITH Z-RAIL® DISCONNECT SYSTEM, FIBERGLASS BASIN

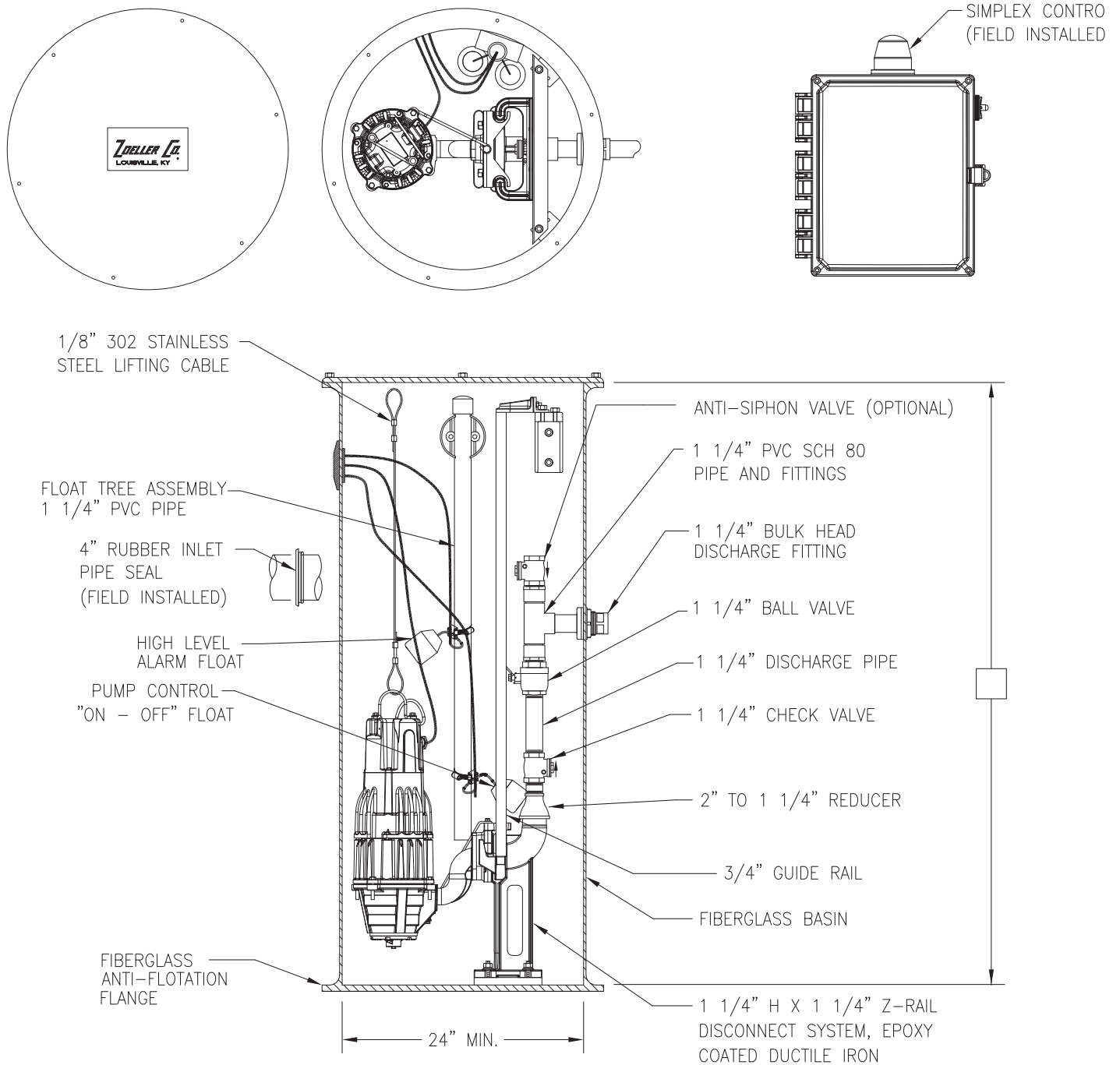

SK3091

Typical Simplex System Includes:

- 1 1.0 or 2.0 HP progressing cavity grinder pump
- 1 Control panel or high water alarm
- 1 Junction box (optional, not shown)
- 2 or 3 Pump control and alarm floats
- 1 Fiberglass basin with solid cover, rail system, valves, discharge piping, float tree and stainless steel lifting cable