

Trusted. Tested. Tough.®



SECTION: Z1.20.300
 ZM1375
 0225
 Supersedes
 0624

MAIL TO: P.O. BOX 16347 • Louisville, KY 40256-0347
 SHIP TO: 3649 Cane Run Road • Louisville, KY 40211-1961
 Tel: (502) 778-2731 • 1 (800) 928-PUMP

Visit our website:
 zoellerengineered.com

Product information presented here reflects conditions at time of publication. Consult factory regarding discrepancies or inconsistencies.



Tested to UL
 Standard UL778. Certified to CSA
 Standard C22.2 No. 108.

6290 SERIES COMMERCIAL SEWAGE PUMPS TECHNICAL DATA



PUMP NAME PLATE HORSEPOWER:	<input type="checkbox"/> 6292	<input type="checkbox"/> 6294	<input type="checkbox"/> 6295
	1/2 HP	1-1/2 HP	2 HP
SOLID SIZE: in (mm)	2" (50 mm)	2" (50 mm)	2" (50 mm)
MINIMUM HEAD: ft. (m)	5.0' (1.5 m)	5.0' (1.5 m)	5.0' (1.5 m)
MAXIMUM HEAD: ft. (m)	40' (12.2 m)	62' (18.9 m)	75' (22.9 m)
MAX.FLOW GPM (L/min) @ MIN. HEAD ft. (m)	135 GPM @ 5' (511 L/min @ 1.5 m)	196 GPM @ 5' (742 L/min @ 1.5 m)	214 GPM @ 5' (810 L/min @ 1.5 m)
DISCHARGE SIZE: VERTICAL FEMALE	<input type="checkbox"/> 2" NPT; Optional Flange, order: <input type="checkbox"/> 3" NPT (10-1306)		

PUMP NET WEIGHT: lbs (kg)	93-96 lbs (42-44 kg)	MOTOR TYPE:	SUBMERSIBLE	
SERVICE FACTOR:	1.0	TYPE SOW POWER CORD LENGTH: ft (m)	25' (7.62 m) <input type="checkbox"/> 50' (15.24m)	
MOTOR DESIGN LETTER:	NEMA B	MOTOR SHAFT:	416 S.S.	
IMPELLER TYPE:	CAST IRON VORTEX	STATOR AND LEAD WIRES INSULATION:	6292	CLASS B
			6294 & 6295	CLASS F
O-RINGS AND COVER GASKET:	VITON	MAXIMUM STATOR TEMPERATURE:	CLASS B	266 °F (130 °C)
RPM:	3450		CLASS F	311 °F (155 °C)

SHAFT SEAL CONSTRUCTION:	STANDARD		UPPER-CARBON / CERAMIC, LOWER-SILICON CARBIDE / CARBON	
	OPTIONAL	<input type="checkbox"/> UPPER	<input type="checkbox"/> SILICON CARBIDE / SILICON CARBIDE	
		<input type="checkbox"/> LOWER	<input type="checkbox"/> SILICON CARBIDE / SILICON CARBIDE	
MOTOR THERMAL SHUTOFF:	THERMAL OVERLOAD SWITCH WITH AUTOMATIC RESET			
MOISTURE DETECTION:	<input type="checkbox"/> OPTIONAL *		MOISTURE SENSING PROBES	
MINIMUM RECOMMENDAD FLUID LEVEL: IN (M)	10" (254 mm)			
MAXIMUM WATER TEMPERATURE:	130 °F (54 °C) 120 °F (49 °C) FOR WD6295			

*Requires a circuit in control panel to function.

ELECTRICAL DATA

MODEL	HP	<input type="checkbox"/> 115 V / 1 Ph		<input type="checkbox"/> 200 V / 1 Ph		<input type="checkbox"/> 230 V / 1 Ph		<input type="checkbox"/> 200 V / 3 Ph		<input type="checkbox"/> 230 V / 3 Ph		<input type="checkbox"/> 460 V / 3 Ph	
		FLA	LRA	FLA	LRA	FLA	LRA	FLA	LRA	FLA	LRA	FLA	LRA
<input type="checkbox"/> 6292	1/2	15.0	52.2	--	--	--	--	6.4	23.6	5.2	24.0	2.9	12.0
<input type="checkbox"/> 6294	1-1/2	--	--	17.8	54.5	13.7	45.7	10.8	45.2	9.5	39.4	4.8	19.7
<input type="checkbox"/> 6295	2	--	--	20.5	54.5	17.1	45.7	14.3	45.2	12.2	39.4	6.1	19.7

Refer to reverse side for Head/Capacity Performance Curves

© Copyright 2025 Zoeller® Co. All rights reserved.

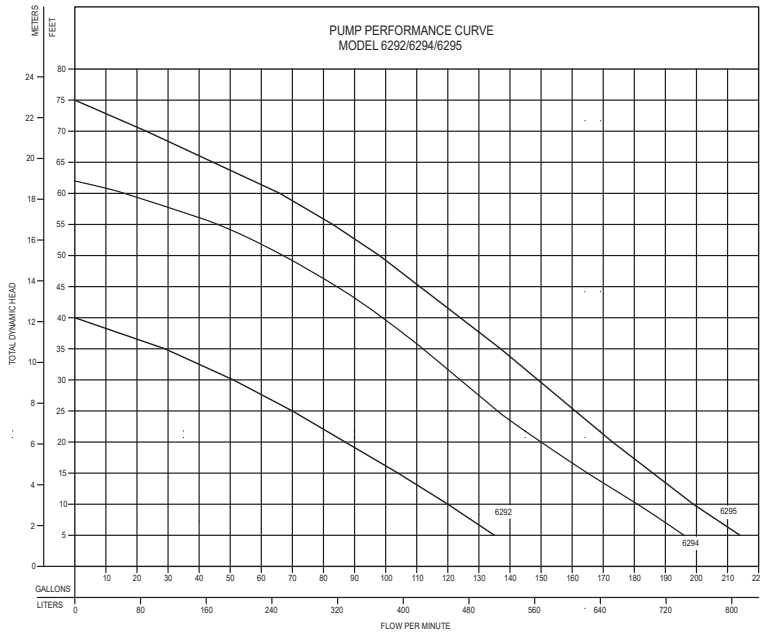

MODEL	6292		6294		6295		
Feet	Meters	Gal.	Liters	Gal.	Liters	Gal.	Liters
5	1.5	135	511	196	742	214	810
10	3.0	120	454	181	685	199	753
15	4.6	104	394	165	625	186	704
20	6.1	87	329	150	568	173	655
25	7.6	70	265	136	515	161	609
30	9.1	51	193	124	469	149	564
35	10.7	29	110	112	424	137	519
40	12.2	--	--	99	375	124	469
50	15.2	--	--	67	254	98	371
55	16.8	--	--	46	174	83	314
60	18.3	--	--	16	61	66	250
70	21.3	--	--	--	--	23	87
Shut-off Head:		40 ft.(12.2m)		62 ft.(18.9m)		75 ft.(22.9m)	

009919

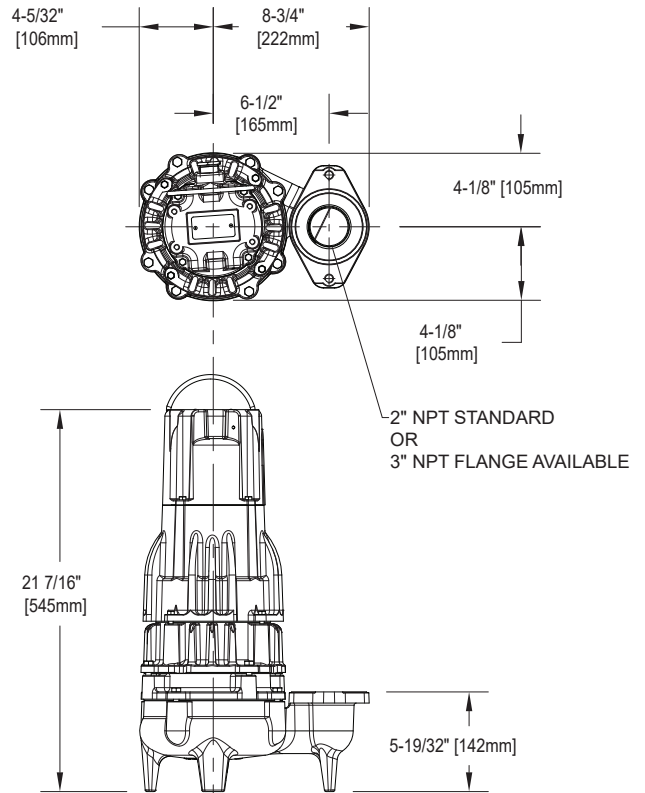

SK1415

Standard all models - 25 ft. (7.6 m) cord - 1/2 HP

6292 MODELS	Control Selection			Listings cCSAus
	Volts	Ph	Amps	
*N6292	115	1	15.0	No ⁽¹⁾
J6292	200	3	6.4	Yes
F6292	230	3	5.2	Yes
G6292	460	3	2.9	Yes

Standard all models - 25 ft. (7.6 m) cord - 1-1/2 HP

6294 MODELS	Control Selection			Listings cCSAus
	Volts	Ph	Amps	
*E6294	230	1	13.7	No ⁽¹⁾
I6294	200	1	17.8	Yes
J6294	200	3	10.8	Yes
F6294	230	3	9.5	Yes
G6294	460	3	4.8	Yes

Standard all models - 25 ft. (7.6 m) cord - 2 HP

6295 MODELS	Control Selection			Listings cCSAus
	Volts	Ph	Amps	
*E6295	230	1	17.1	No ⁽²⁾
I6295	200	1	20.5	Yes
J6295	200	3	14.3	Yes
F6295	230	3	12.2	Yes
G6295	460	3	6.1	Yes

* Molded Plug

All pumps are available with optional moisture sensors. Seal Fail indicator light available in NEMA 4X control panels.

(1) CSA Approval with 15 Amp plug.

(2) CSA Approval with 20 Amp plug.

FEATURES

- Durable epoxy coated cast iron construction
- Motor - 1/2 hp - 2 hp, 60 hz, 3450 rpm, 1 ph or 3 ph, oil filled, hermetically sealed, automatic reset, thermal overload protected (1 ph)
- Bearings - upper and lower ball bearings
- Stainless steel motor shaft
- Dual mechanical shaft seals - upper carbon/ceramic, lower silicon carbide/carbon. Optional seal materials available
- Viton o-ring seals and cover gasket
- Impeller - non-clogging cast iron vortex design passes 2" (50 mm) spherical solids
- 25 Foot (7.6 M) listed 3-wire neoprene cord and plug
- No screens to clog
- Stainless steel screws, bolts and handle
- 2" Npt discharge with 3" flange available
- Corrosion resistant powder coated epoxy finish
- Moisture sensors available for early warning of seal failure. (Optional)
- 100% Computerized tested



All installation of controls, protection devices and wiring should be done by a qualified licensed electrician. All electrical and safety codes should be followed including the most recent National Electrical Code (NEC) and the Occupational Safety and Health Act (OSHA).