

Trusted. Tested. Tough.®



SECTION: Z1.10.500
ZM1499
0225
Supersedes
0621

MAIL TO: P.O. BOX 16347 • Louisville, KY 40256-0347
SHIP TO: 3649 Cane Run Road • Louisville, KY 40211-1961
Tel: (502) 778-2731 • 1 (800) 928-PUMP

Visit our website:
zoellerengineered.com

Product information presented here reflects conditions at time of publication. Consult factory regarding discrepancies or inconsistencies.

6160 & 6180 SERIES COMMERCIAL EFFLUENT PUMP DIMENSIONAL DATA Floor Mounted

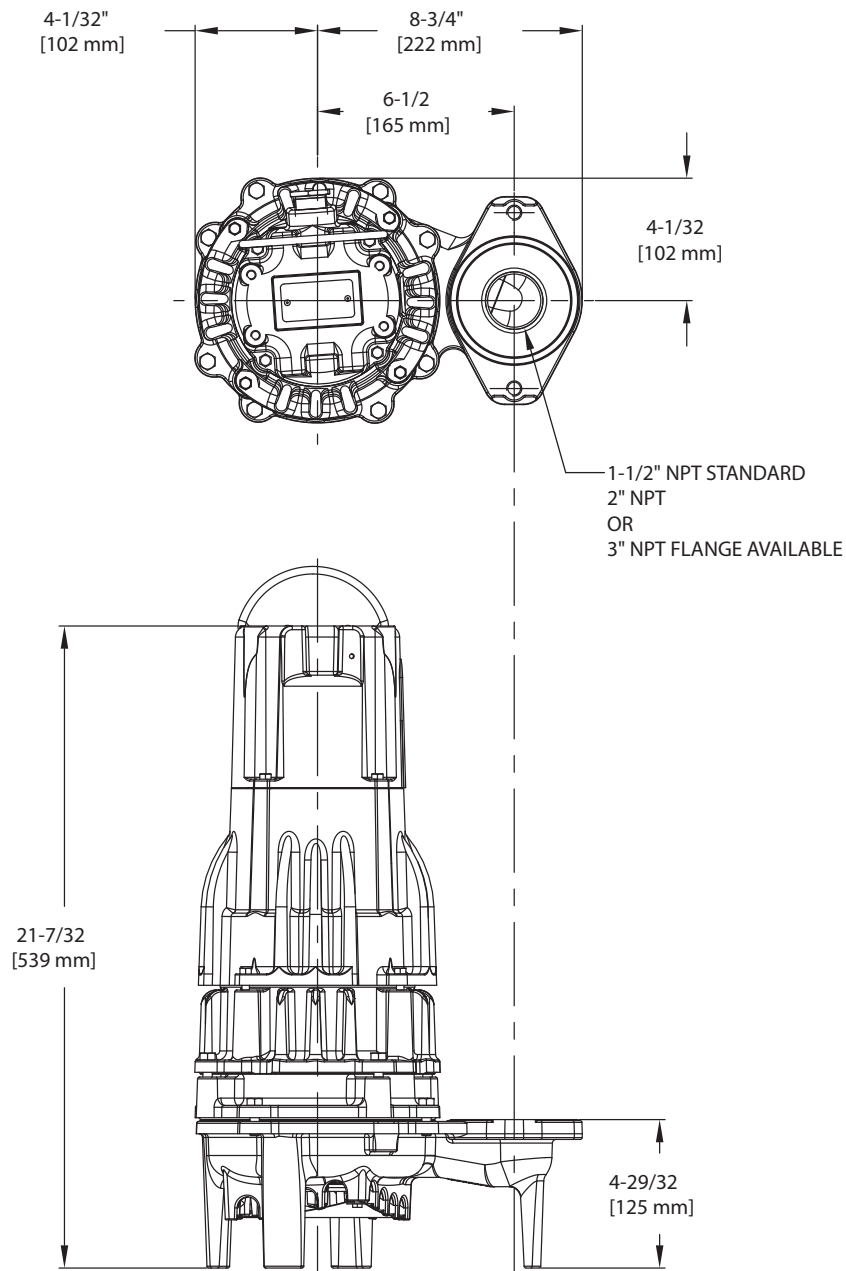

See ZM1372 (6160) & ZM1373 (6180) for listed models

SK1413

6160 & 6180 SERIES COMMERCIAL EFFLUENT PUMP

DIMENSIONAL DATA

1-1/2", 2" & 3" Rail Mounted
Z Rail® Disconnect System

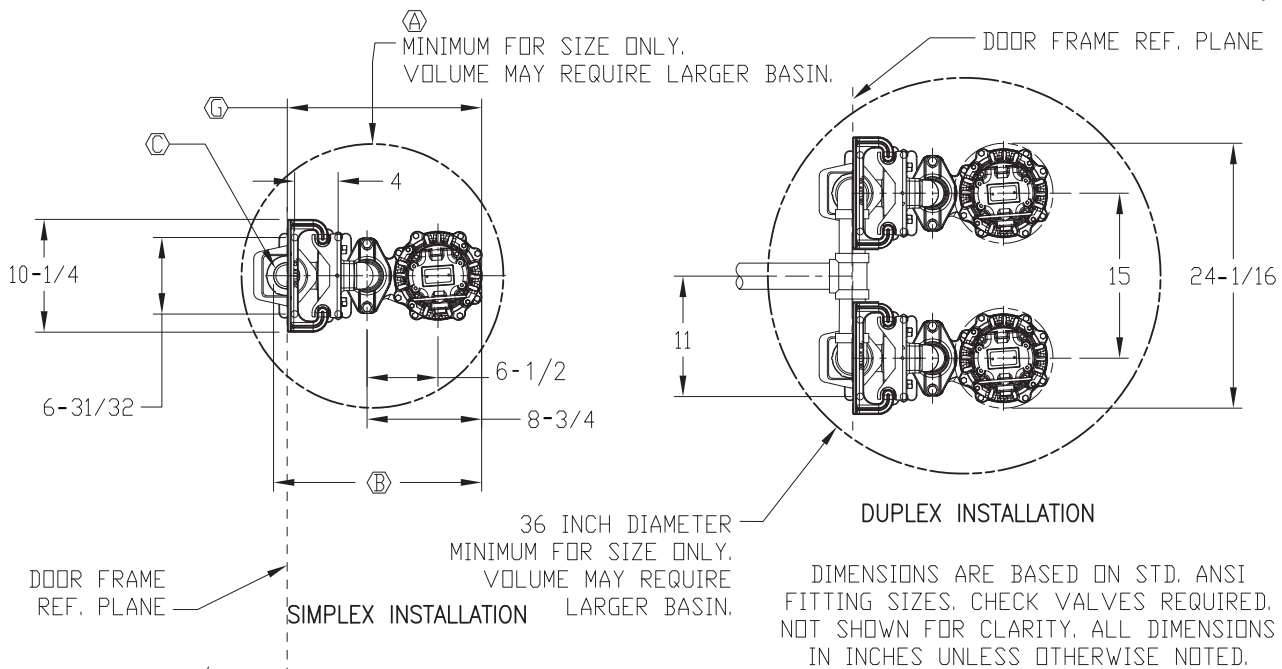

DIMENSIONS ARE BASED ON STD. ANSI FITTING SIZES. CHECK VALVES REQUIRED. NOT SHOWN FOR CLARITY. ALL DIMENSIONS IN INCHES UNLESS OTHERWISE NOTED.

DISCHARGE	A	B	C	D	E	F	G
1-1/2 OR 2 INCH	24	19-1/16	2	1-3/4	22-15/16	26-1/16	17-13/16
3 INCH	30	20-13/16	3	4-3/8	25-9/16	28-11/16	18-3/8

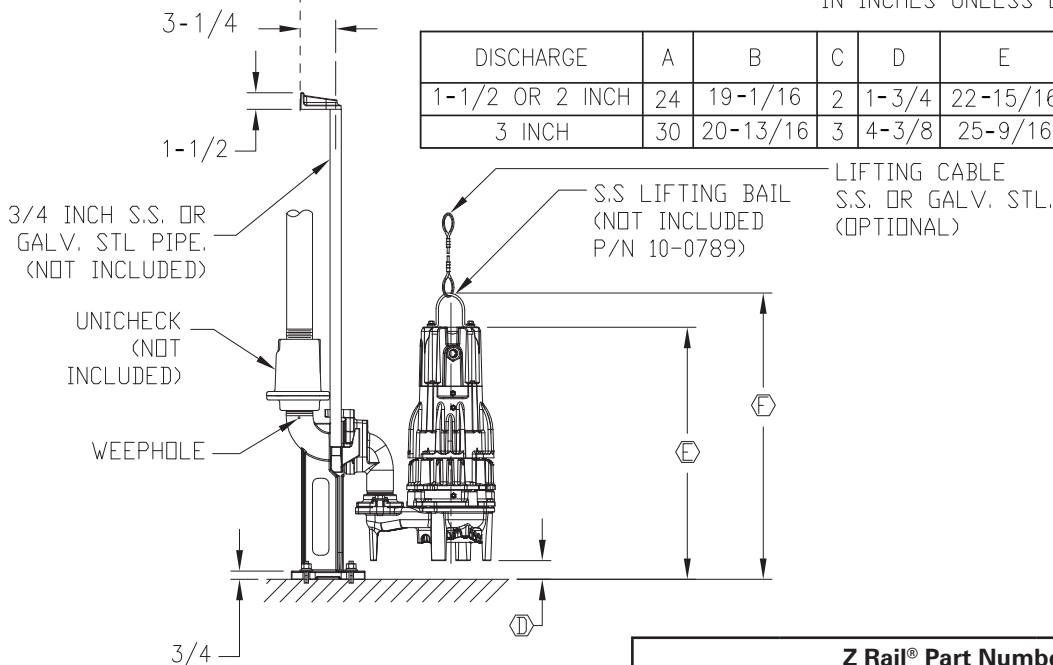

SK2978

Z Rail® Part Numbers		
Discharge Size	Ductile Iron Upper Bracket	Stainless Steel Upper Bracket
1.5"	39-0131	39-0132
2.0"	39-0128	39-0129
3.0"	39-0122	39-0123
10-0789 Lifting Bail		

*Intermediate rail bracket required every 12' of basin depth. Refer to ZM1347

See ZM1372 (6160) & ZM1373 (6180) for listed models