

Trusted. Tested. Tough.®



SECTION: Z1.20.200
ZM1374
0225
Supersedes
1223

MAIL TO: P.O. BOX 16347 • Louisville, KY 40256-0347
SHIP TO: 3649 Cane Run Road • Louisville, KY 40211-1961
Tel: (502) 778-2731 • 1 (800) 928-PUMP

Visit our website:
zoellerengineered.com

Product information presented here reflects conditions at time of publication. Consult factory regarding discrepancies or inconsistencies.



6280 SERIES COMMERCIAL SEWAGE PUMPS TECHNICAL DATA



	<input type="checkbox"/> 6284
PUMP NAME PLATE HORSEPOWER:	1 HP
SOLID SIZE: in (mm)	2" (51mm)
MINIMUM HEAD: ft. (m)	5.0' (1.5m)
MAXIMUM HEAD: ft. (m)	35' (10.7m)
MAX.FLOW GPM (L/min) @ MIN. HEAD ft. (m)	179 GPM @ 5' (678 L/min @ 1.5m)
DISCHARGE SIZE: VERTICAL FEMALE	<input type="checkbox"/> 2" NPT; Optional Flange, order: <input type="checkbox"/> 3" NPT (10-1306)

PUMP NET WEIGHT: lbs (kg)	89 lbs (40 kg)	MOTOR TYPE:	SUBMERSIBLE
SERVICE FACTOR:	1.0	TYPE SOW POWER CORD LENGTH: ft (m)	25' (7.62m) <input type="checkbox"/> _____'
MOTOR DESIGN LETTER:	NEMA B	MOTOR SHAFT:	416 S.S.
IMPELLER TYPE:	CAST IRON VORTEX	STATOR INSULATION:	CLASS B
O-RINGS AND COVER GASKET:	VITON	LEAD WIRES INSULATION:	CLASS B
RPM:	1750	MAXIMUM STATOR TEMPERATURE:	266 °F (130 °C)

SHAFT SEAL CONSTRUCTION:	STANDARD	UPPER-CARBON/CERAMIC, LOWER-SILICON CARBIDE/ CARBON
	OPTIONAL <input type="checkbox"/> UPPER <input type="checkbox"/> LOWER	<input type="checkbox"/> SILICON CARBIDE / CARBON <input type="checkbox"/> SILICON CARBIDE / SILICON CARBIDE <input type="checkbox"/> SILICON CARBIDE / SILICON CARBIDE
MOTOR THERMAL SHUTOFF:	STANDARD (Single Phase Only)	THERMAL OVERLOAD SWITCH WITH AUTOMATIC RESET
MOISTURE DETECTION:	<input type="checkbox"/> OPTIONAL *	MOISTURE SENSING PROBES
MINIMUM RECOMMENDED FLUID LEVEL: in (m)		10" (0.25m)
MAXIMUM WATER TEMPERATURE:		130 °F (54 °C)

*Requires a circuit in control panel to function.

ELECTRICAL DATA

MODEL	HP	<input type="checkbox"/> 200V/1Ph		<input type="checkbox"/> 230V/1Ph		<input type="checkbox"/> 200V/3Ph		<input type="checkbox"/> 230V/3Ph		<input type="checkbox"/> 460V/3Ph	
		FLA	LRA	FLA	LRA	FLA	LRA	FLA	LRA	FLA	LRA
<input type="checkbox"/> 6284	1	9.3	22.0	8.9	24.0	5.5	21.4	5.0	15.5	2.6	9.0

Refer to reverse side for Head/Capacity Performance Curves

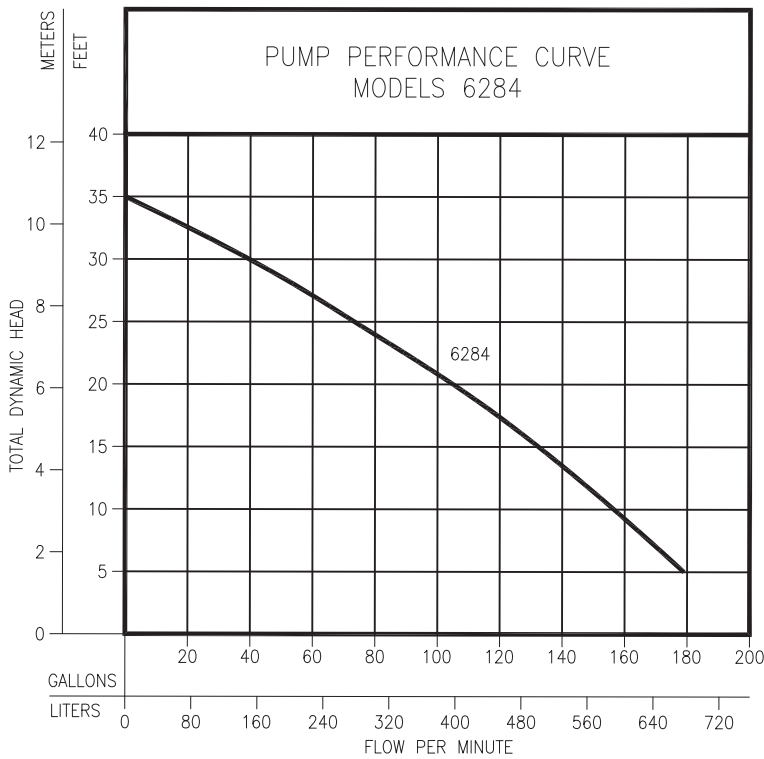

MODELS		6284	
Feet	Meters	Gal.	Liters
5	1.5	179	678
10	3.0	157	594
15	4.6	133	503
20	6.1	106	401
25	7.6	73	276
30	9.1	42	159
Shut-off Head		35 ft. (10.7m)	

009927

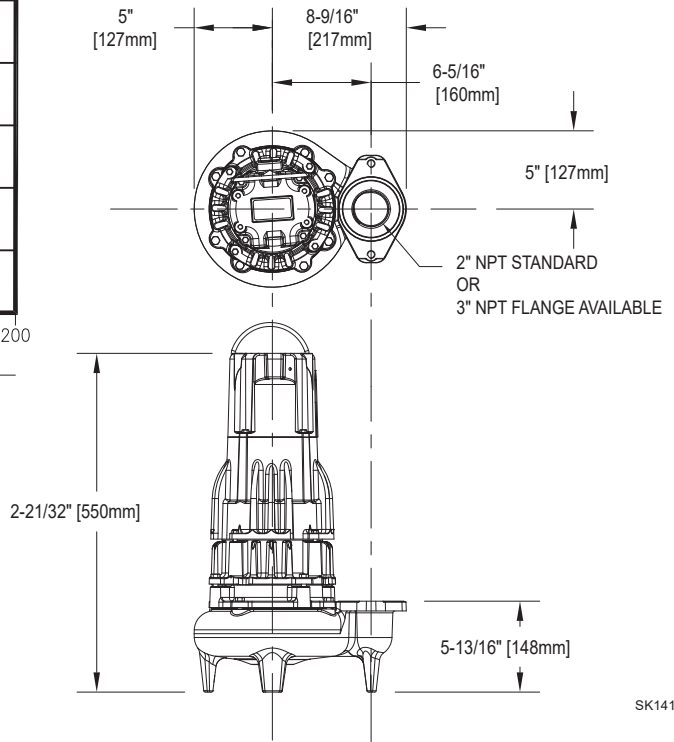

SK1414

Standard all models - 25 ft. cord - 1 HP

6284 MODELS	Control Selection			Listings
	Volts	PH	Amps	cCSAus
* E6284	230	1	8.9	Yes
I6284	200	1	9.3	Yes
J6284	200	3	5.5	Yes
F6284	230	3	5.0	Yes
G6284	460	3	2.6	Yes

* Molded Plug
Double Seal pumps are available with optional moisture sensors. Seal Fail indicator light available in NEMA 4X control panels.

FEATURES

- Durable epoxy coated cast iron construction.
- Motor - 1 hp, 60 hz, 1750 rpm, 1 ph or 3 ph, oil filled, hermetically sealed, automatic reset, thermal overload protected (1 ph).
- Bearings - upper and lower ball bearings.
- Stainless steel motor shaft.
- Dual mechanical shaft seals - upper carbon/ceramic, lower silicon carbide/carbon. Optional seal materials available
- Viton o-ring seals and cover gasket.
- Impeller - non-clogging cast iron vortex design passes 2" spherical solids.
- 25 Foot UL listed 3 wire neoprene cord and plug. Longer cords available in lengths of 35-50 feet.
- No screens to clog.
- Stainless steel screws, bolts and handle.
- 2" NPT discharge with 3" flange available.
- Corrosion resistant powder coated epoxy finish.
- Moisture sensors available for early warning of seal failure. (Optional)
- 100% Computerized tested.

CAUTION

All installation of controls, protection devices and wiring should be done by a qualified licensed electrician. All electrical and safety codes should be followed including the most recent National Electric Code (NEC) and the Occupational Safety and Health Act (OSHA).